

SIDE VIEW

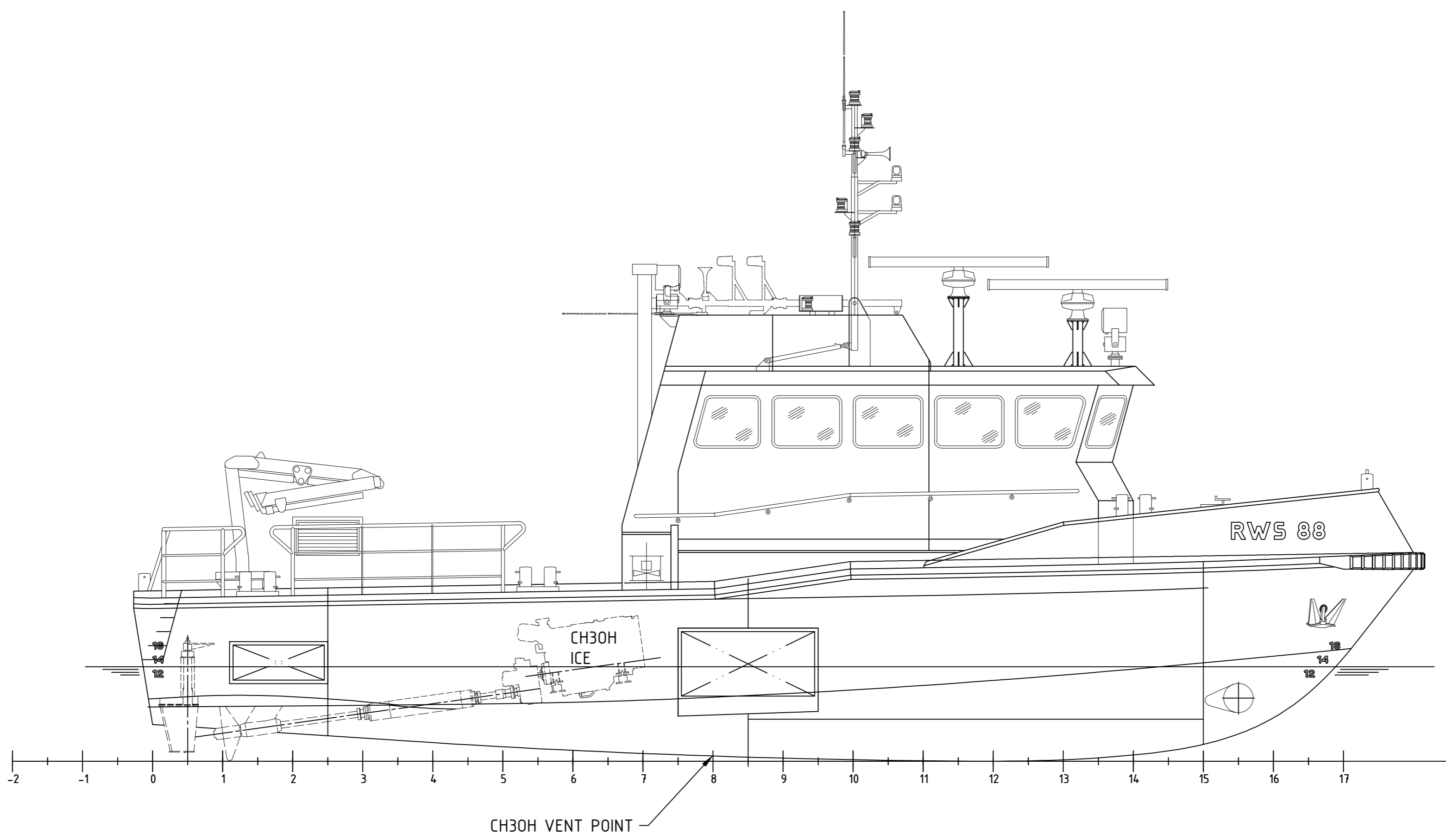

APPROX. 2400 A.B

DRY-DISCONNECT
BUNKER CONNECTION PS

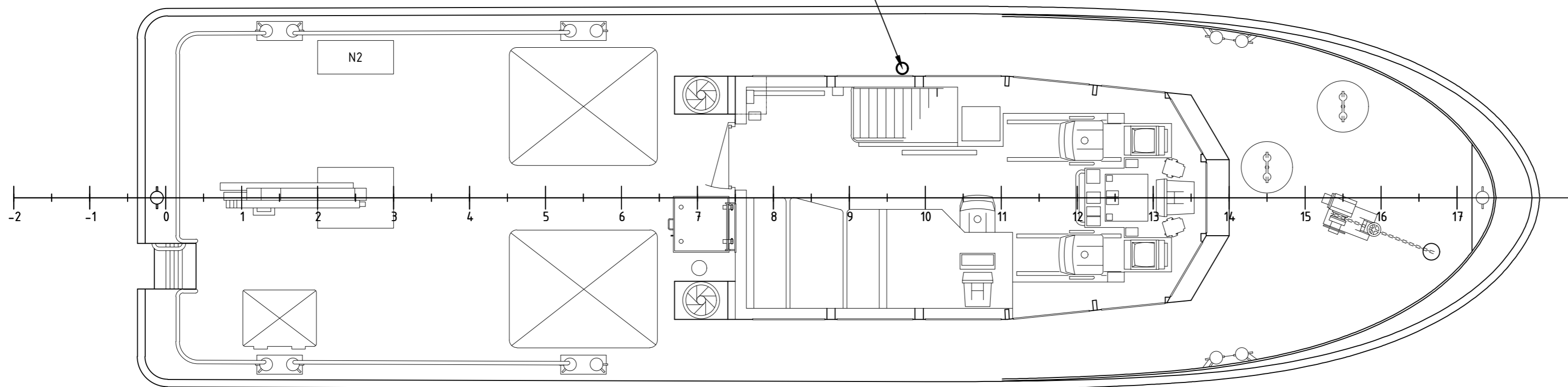

APPROX. 900 A.B

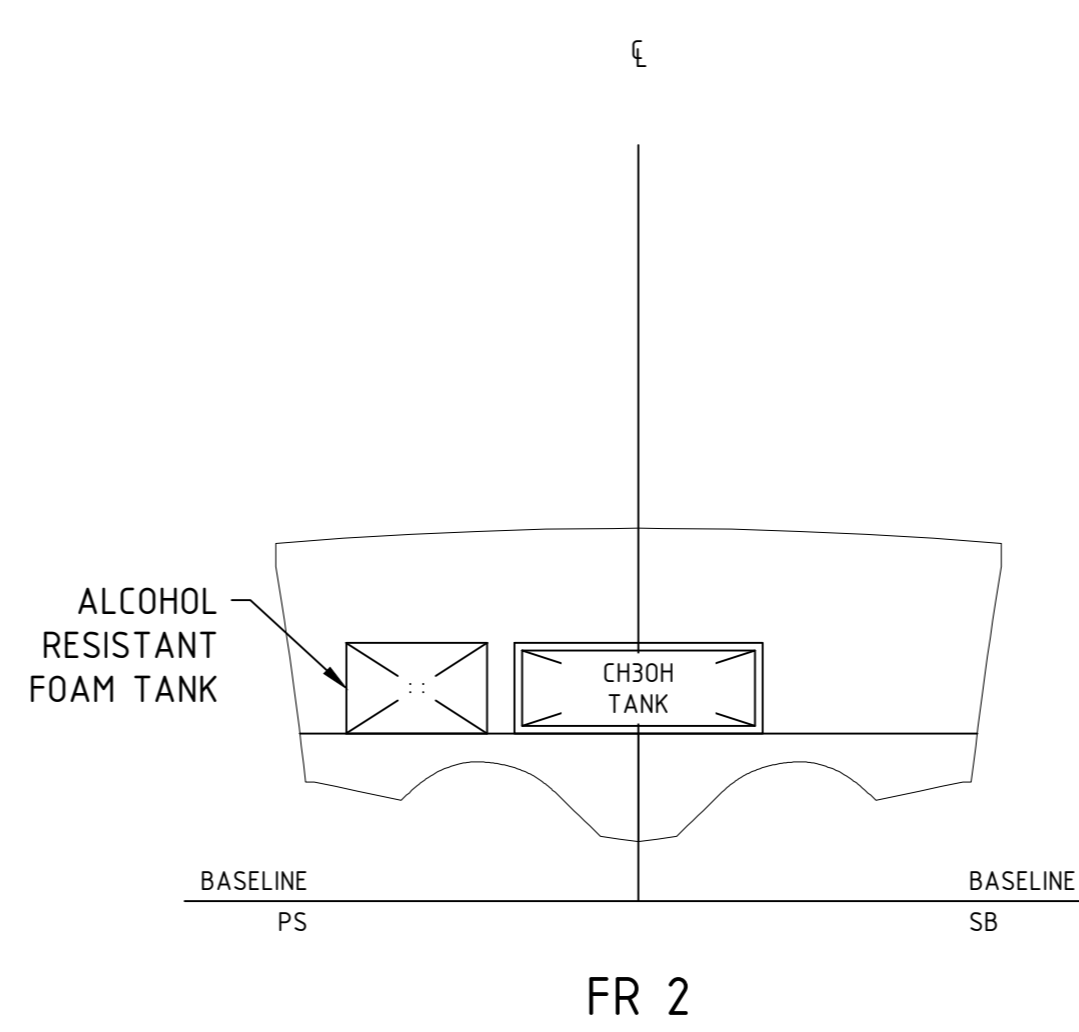
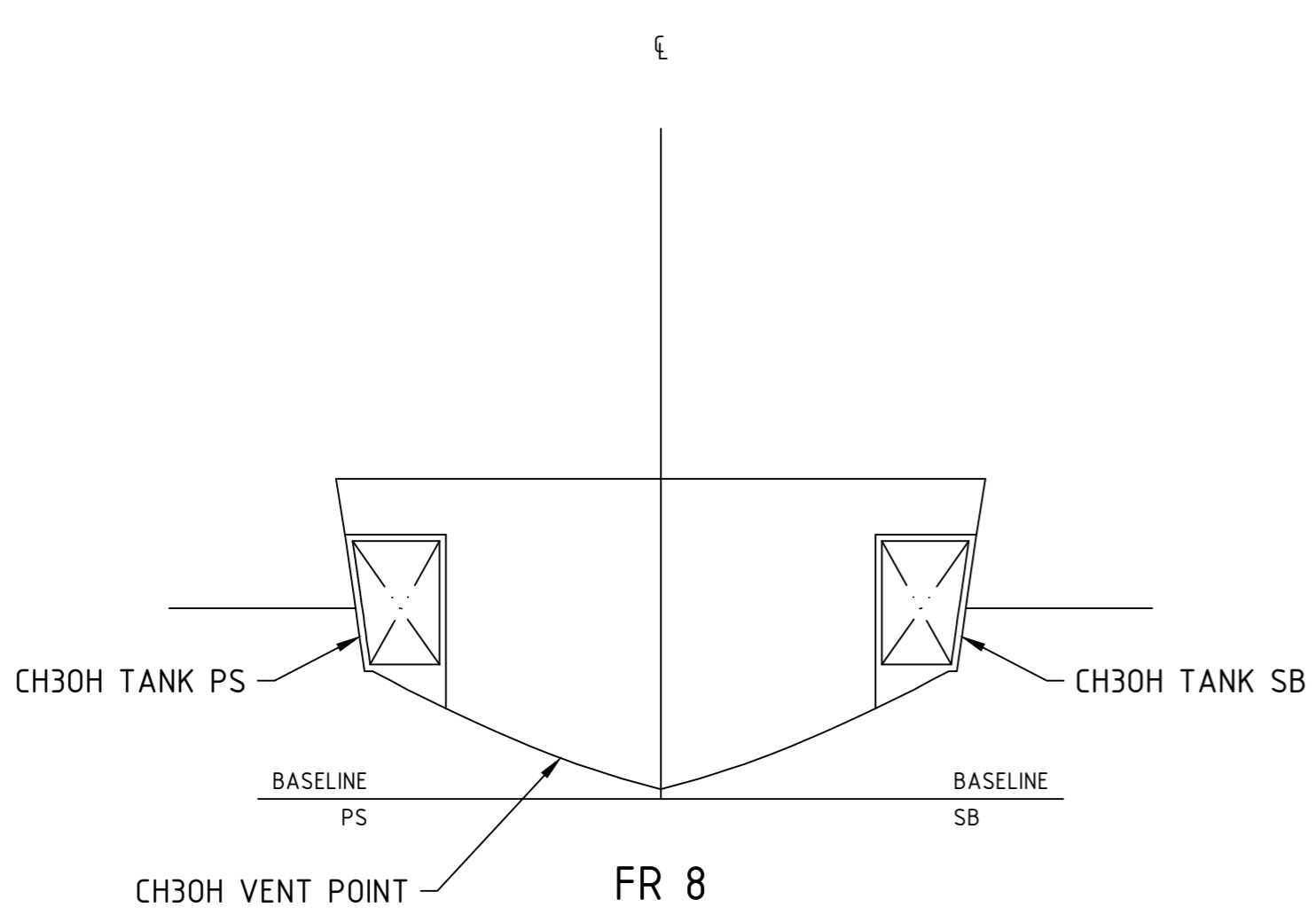
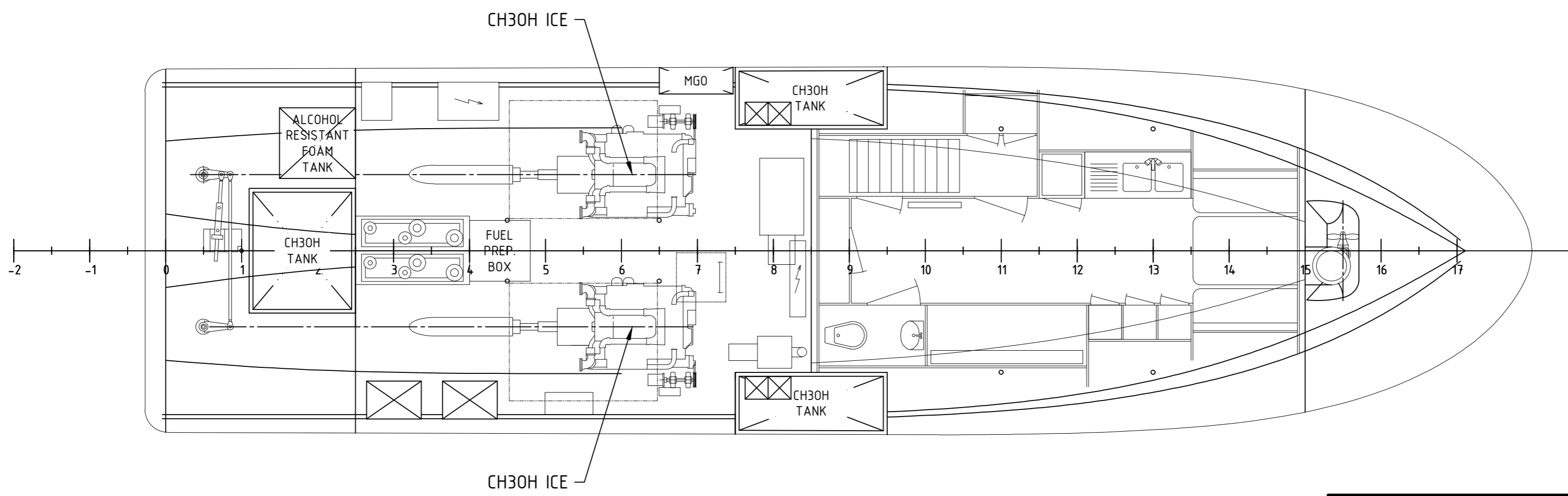

MAIN PARTICULARS

LENGTH OVER ALL	18.47	[m]
BREEDTE MOULDED	5.00	[m]
DEPTH UPPER DECK	4.84	[m]
DRAUGHT DESIGN APPROX.	1.35	[m]
ENGINE OUTPUT	830	[kW]
DISPLACEMENT	66	[t]

BUILDER DAMEN SHIPYARDS

0	FIRST ISSUE	SA	JVD	NDV	20220328
REV	DESCRIPTION	DRAWN	CHECK	APPR.	DATE

CLIENT PROJECT NO.: CLIENT DRAWING NO.:

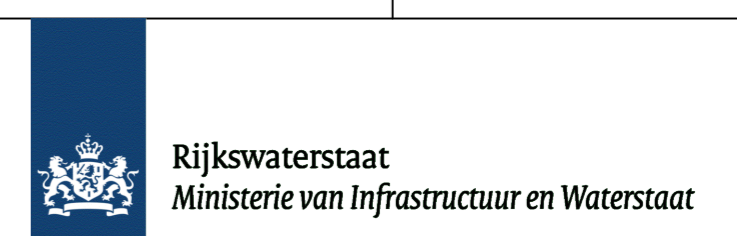

<p>T: +31 (0) 88 024 37 00 I: www.c-job.com E: info@c-job.com</p>	CLIENT: Rijkswaterstaat	YARD NO.: -	CLASS NO.: -
	PROJECT NUMBER: 21516	DRAWING NUMBER: 000-001	STATUS: PRELIMINARY
TITLE: GENERAL ARRANGEMENT RWS 88			
PROJECTION:	DIM. UNIT: mm	REV.: 0	SHEET: SH1-1
COPYRIGHT OF C-JOB. THIS DOCUMENT REMAINS NO PART THEREOF MAY BE DISCLOSED, COPIED, DUPLICATED OR IN ANY OTHER WAY MADE USE OF EXCEPT WITH THE APPROVAL OF C-JOB.		SCALE: 1:50	FORMAT: A1