



SEVENTH FRAMEWORK
PROGRAMME
THEME 7 TRANSPORT



Grant Agreement Number:

233597

Acronym:

PROLOGUE

Full Title:

PROmoting real **Life** **O**bservations for **G**aining
Understanding of road user behaviour in **E**urope

Funding Scheme:

Collaborative project small scale

Project Co-ordinator

SWOV Institute for Road Safety Research

Duration:

01/08/2009 to 31/07/2011

Project Website:

www.prologue-eu.eu



In-vehicle and site-based observations of vehicles and cyclists A small-scale ND study in the Netherlands

Deliverable D3.4

Authors:

Michiel Christoph & Nicole van Nes (SWOV), Jasper Pauwelussen,
Remco Mansvelders, Richard van der Horst & Marika Hoedemaeker
(TNO)

Status:

Final draft submitted to EC

Date:

20 December 2010

Dissemination Level: Public

Project Consortium

1		SWOV Institute for Road Safety Research (project co-ordinator)	NL
2		CERTH/HIT Hellenic Institute of Transport	GR
3		KfV Kuratorium für Verkehrssicherheit	A
4		Loughborough University	UK
5		Or Yarok	ISR
6		Nederlandse Organisatie voor Toegepast Natuurwetenschappelijk Onderzoek - TNO	NL
7		TØI Institute of Transport Economics	NO
8		Test & Training International Planning and Service GmbH	A
9		Universitat de València	ES

Document Reference

Christoph, M., Nes, N. (SWOV), Pauwelussen, J., Mansvelders, R., van der Horst, A.R.A. and Hoedemaeker, M. (TNO) (2010). *In-vehicle and site-based observations of cyclists; a small-scale ND field trial in the Netherlands*. PROLOGUE Deliverable D 3.4. TNO, Soesterberg, The Netherlands.

Abstract

The main objective of the project PROLOGUE (PROmoting real Life Observations for Gaining Understanding of road user behaviour in Europe) is to explore the feasibility and usefulness of a large-scale European naturalistic driving observation study. The work described in this deliverable focused on the feasibility of using and combining two observation methods, site-based observation and in-vehicle observation, for naturalistic driving analysis. In this study the strengths and weaknesses of each method were analyzed and the differences between measures that were calculated by both methods were compared to consider the combined results.

The two different observation methods studied the interaction between car drivers turning right and cyclists going straight at an intersection, which was equipped with cameras. For the site-based study one camera was used that had a bird's eye view on the intersection. The video data were processed manually and automatically. The results of the two ways of analysis were compared. The instrumented cars were equipped with a data acquisition system (DAS) and sensors including a GPS logger and a camera.

The results of the site-based observations showed that the manual processing seemed to be more accurate than the automatic processing. However, the processing time was much larger for manual analysis. Having a top view camera or more cameras with different viewpoints could improve the accuracy of automatic processing by providing the ability to detect the sizes of the road users and therefore the road user type.

The in-vehicle measurement showed that drivers show different driving behaviour when making the right turn manoeuvre from a halted situation compared to a non-halted situation. This implies that drivers adapt their behaviour and compensate for the more dangerous situation by driving slower and looking more often.

The results of the speed measure comparison between the site-based and in-vehicle study showed that the average speeds for both studies were similar. However, the speed profile that was measured in the in-vehicle study was less smooth than the speed pattern that was derived in the site-based study. This is explained by the noisy GPS signal on which the in-vehicle speeds are based.

The value of combining the two observation methods is twofold. At first it offers the opportunity to enrich the information from one study with complementary observations from the other study. Secondly, it offers the opportunity to *validate* measures from the individual studies.

This study showed that each type of study has its unique values. From in-vehicle data it is possible to look in detail at the driving behaviour of the participants over time and in different natural situations. The video data allows looking over the shoulder of the driver and observer where drivers are looking or what they are paying attention to. By analyzing their glancing behaviour, we know when and how often drivers look at other vulnerable road users to estimate their position and speed and to be able to anticipate.

For a future large scale naturalistic driving study it could be valuable to add a number of sites with site-based observation. Two main areas are identified that would benefit from these complementary observations. One research area is when studying the interaction between drivers and vulnerable road users. Another research area that would benefit from the complementary observations is research questions related to infrastructure – as these are by nature related to a specific site like an intersection, a lane merge or a roundabout. The site-based observation allows to observe the traffic flow, the in-vehicle observation could add (for the overlapping cases) information on looking behaviour or other in-vehicle behaviours as well as additional vehicle data like accelerations.

Table of Contents

Executive Summary	5
1 Introduction	9
1.1 <i>PROLOGUE</i>	9
1.2 <i>In-vehicle observation versus site-based observations</i>	9
1.3 <i>Focus of the study: Intersections and cyclists</i>	10
1.4 <i>Objectives of the study</i>	11
1.5 <i>Study design</i>	11
2 Technology used	15
2.1 <i>Site-based observation</i>	15
2.2 <i>In-vehicle observation</i>	17
3 Methodology	24
3.1 <i>Site-based observation</i>	24
3.2 <i>In-vehicle observation</i>	44
4 Results	54
4.1 <i>Site-based observation</i>	54
4.2 <i>In-vehicle observation</i>	67
4.3 <i>Combining the two observations</i>	72
5 Summary & discussion	76
5.1 <i>Site-based observation</i>	76
5.2 <i>In-vehicle observation</i>	77
5.3 <i>Overall: the potential of combining site-based and in-vehicle observations</i>	83
6 References	86
Appendix I: Informed consent	87
Overeenstemming betreffende medewerking aan onderzoek	87
List of Figures	91
List of Tables	93
List of Abbreviations	94

Executive Summary

The main objective of the project PROLOGUE (PROmoting real Life Observations for Gaining Understanding of road user behaviour in Europe) is to explore the feasibility and usefulness of a large-scale European naturalistic driving observation study. The work described in this deliverable focused on the feasibility of using and combining two observation methods for naturalistic driving analysis, site-based observation and in-vehicle observation. The separate methods have their strengths and weaknesses. In this study these strengths and weaknesses were analyzed. Also the measures that were calculated by both methods were compared to consider the combined results.

The main objectives of this study were:

1. To study interactions between car drivers turning right, divided into cars that had a green (non-halted) and red (halted) traffic light, and cyclists going straight.
2. To compare speed measurements from site-based study and in-vehicle study (validation)

The interaction between car drivers turning right and cyclists going straight was observed at an intersection, which was equipped with cameras. For the site-based study a camera was used that had a bird's eye view on the intersection. The video data were processed manually and automatically. The results of the two ways of analysis were compared. The instrumented cars were equipped with a data acquisition system (DAS) and sensors including a GPS logger and a camera.

Site-based observation

The results of the site-based observations showed that the manual processing seemed to be more accurate than the automatic processing. However, the processing time was much larger for manual analysis.

Differences between manual and automatic processing that caused some small errors between the results of both approaches were:

- The vehicles that turned right at the intersection included cars and trucks in the automatic processing. To determine the different types of road users extra filtering was needed.
- In the automatic processing mopeds were also counted as cyclists, while in the manual processing these were excluded.
- Targets behind other targets were sometimes not tracked or tracked twice in the automatic processing, because objects were merged to one or suddenly the tracking switched between several objects counting objects twice.
- Specifically when there was a group of bicyclists, the problem of visual overlap occurred and the separate bicyclists were merged to one object.
- When an object becomes static, the object will be included into the background estimation. The object will disappear. When the object is moving again, there will be a ghost object at the position where it was standing still, because the background estimation differs from the real background.
- To check the vehicles that turned right, a certain region (from the top view) was determined. If vehicles crossed this region, it was assumed that this vehicle turned right at the crossing. The accuracy of the automatic counting thus largely depended on the determination of this region. If the detection of a vehicle was not that accurate, the path of this vehicle could have been outside the detection region and thus was not counted as a vehicle turning right, although the vehicle actually turned right in reality. For the cyclists it was also seen that the cyclists sometimes did not follow the traffic rules, but drove against the traffic flow.

Despite the errors that were found, it should be emphasized that automatic processing also has a great advantage over manual processing. The processing time, after having prepared the automatic algorithms, takes much less time than manual processing.

The speed of the right turning cars was estimated in the manual data processing. With respect to TTC and PET values, it is concluded that the non-halted turning cars are more involved in conflicts with bicyclists than the cars that start from a halted position. This can be explained by a specific feature in the signalization scheme with a pre-start for bicyclists at the beginning of the green phase.

In-vehicle observation

The results of the in-vehicle study showed that both direct and indirect glance behaviour increased in terms of duration and frequency in the halted situation compared to the non-halted situation. This supports the idea that vehicle drivers might adapt their driving behaviour and take safety measures to compensate for a less accurate mental image of the presence of cyclists. Additional support for this idea comes from the speed and lateral acceleration measures. Both speed and lateral accelerations are lower in the halted situation compared to the non-halted situation. Crossing the Conflict Area with a lower speed gives the vehicle drivers more time to look for cyclists that might be on a conflicting path.

It is important to be aware of the limitations of these results. At first, the total number of the specific right turn manoeuvres included in the analysis is small (N=11). A larger number of subjects would increase the reliability of the results. Second, the driving behaviour was observed at a single intersection. To ensure the observed behaviour was not induced by other features of the intersection, driving behaviour needs to be observed at multiple intersections. Finally, drivers' glance behaviour was coded manually by a single data coder. To increase the reliability of the glance behaviour data, several options are possible. Glance behaviour could be coded by multiple coders to assess inter-observer reliability. Another option would be to use technology (like an eye tracker or automated glance behaviour coding) to increase the reliability of the glance behaviour analysis.

Based on the results of the in-vehicle data, it can be concluded that drivers seem to show different driving behaviour when making the right turn manoeuvre from a halted situation compared to a or non-halted situation. This could imply that drivers adapt their behaviour to the situation and compensate for the more dangerous situation by driving slower and looking more. Based on the results of this study it is not possible to conclude if the change in behaviour compensates sufficiently for possible differences in safety between the two situations.

Combination of site-based and in-vehicle observation

The results of the speed measure comparison between the site-based and in-vehicle study showed that the average speeds for both studies were similar. However, the speed that was measured in the in-vehicle study was less smooth than the speed that was derived in the site-based study.

Lessons learned

The performance of this combined site-based and in-vehicle trial provided useful knowledge and experience for developing a large scale Naturalistic Driving trial.

From the site-based results it was concluded that with automatic processing it was sometimes difficult to determine the different road users. This sometimes caused inaccurate counting results with respect to the manual processing. Having a top view camera or more cameras with different viewpoints could improve the accuracy of automatic processing by providing the ability to detect the sizes of the road users and therefore the road user type. This will also result in a proper determination of the road user's path, which is needed to calculate the correct travelling speed, Time-To-Collision and Post Encroachment Time.

Furthermore, automatic processing will only be useful if it is able to detect moving objects and objects standing still for a few seconds. Also, if there is a visual overlap, objects could be merged to one object. Having more cameras or other information like for example, loop detection, radar or laser scanner information could improve the accuracy of the traffic intensity.

The main lessons learned from the in-vehicle study relate to the equipment. Based on these experiences recommendations for the DAS for a large scale study have been developed. At first it is of major importance to have a reliable power source for the DAS. Unforeseen irregularities in the mechanism that switch the DAS between different power modes should not lead to any discomfort for the participant (e.g. exhausted starter battery) and should minimize the amount of data lost. Secondly, the specifications of the sensors used should match the criteria set by the research design. Thirdly, in most cases the installation of the DAS would need to be done by professionals because the DAS will need a permanent power supply (hardwired to the vehicle's electrical system). As subcontracting involves external costs, the amount of time and the level of skills needed from professionals for installing a DAS and peripheral sensors should be minimized when selecting or developing a DAS for a Naturalistic Driving study. Finally, Naturalistic Driving studies can produce large amounts of data, and in particular the video data can be very large. Although the storage capacity of hard drives increased rapidly over the decennia, data will need to be retrieved from the vehicle on a regular basis which can be a time consuming activity. A well planned structure of the data and easy accessibility will facilitate the analysis and reduce the time needed to prepare the data for analysis. As manual video coding is very labour intensive, the amount of video coding should be minimized. In some cases extra sensors (e.g. an eye tracker) or automated video coding *tools (machine vision)* could reduce the amount of video coding needed.

Conclusions and potential for up scaling

This study showed that each type of study has its unique values. From in-vehicle data it is possible to look in detail at the driving behaviour of the participants over time and in different natural situations. The video data allows looking over the shoulder of the driver and observer where drivers are looking or what they are paying attention to. By analyzing their glancing behaviour, we know when and how often drivers look at other vulnerable road users to estimate their position and speed and to be able to anticipate.

From the site-based video data information can be added about the position and speed of other road users surrounding the participant's vehicle. Also the site-based data could provide information about how other drivers, non participants of the in-vehicle study, behave at that particular site. This allows relating the behaviour of the participant to the behaviour of non-participants, which could be used for generalising the results.

For a future large scale naturalistic driving study it could be valuable to add a number of sites with site-based observation. Two main areas are identified that would benefit from these complementary observations. One research area is when studying research questions about the interaction between drivers and vulnerable road users. Another research area that would benefit from the complementary observations is research questions related to infrastructure. When setting up such a large scale study, it is extremely

important to carefully define the overlapping cases required and to carefully select the participants and the sites in relation to each other to make sure the required cases will be obtained.

1 Introduction

1.1 PROLOGUE

The main objective of the project PROLOGUE (PROmoting real Life Observations for Gaining Understanding of road user behaviour in Europe) is to explore the feasibility and usefulness of a large-scale European naturalistic driving observation study. One of the main activities in the PROLOGUE project is a series of small-scale field trials intended to demonstrate the potential usefulness of naturalistic data collection in practice. They also intend to serve as pilot studies for a future large-scale naturalistic study by experiencing possibilities and limitations of the data collected by the various instruments, by identifying relevant issues related to implementation and management, by evaluating the collected data in association with safety measures, and by identifying potential problems and gaps in the collected data and the various data reduction and data analysis methods.

This report describes the Dutch field trial. The objective in this trial was to explore the value and feasibility of combining two observation methods: site-based observation and in-vehicle observation. Each method has strength and weaknesses but a main question is whether the methods complement each other to get a more comprehensive understanding of behaviour in traffic?

This specific focus of the Dutch field trial relates to the work that was done in WP1 and WP2 of PROLOGUE. In WP1 the research areas for a large-scale European naturalistic driving observation study are identified. Deliverable 1.1 and 1.3 address the need to explore the value of combining the two complementary observations methods. In WP2 the technical, methodological issues and requirements of naturalistic driving studies were described. The Dutch field trial is focussed on two different ways of data collection in a naturalistic study. The in car methods and equipment requirements are described in detail deliverable 2.1, but the equipment necessary for on site data collection is not described. The results of this study can add to that as well as new insights into the metrics that can be measured by using on site data collection (described in deliverable 2.2). The Dutch field trial is unique in that it not only describes a site-based and in vehicle study, but that the two methods are seen as complementary.

1.2 In-vehicle observation versus site-based observations

In the IAAV study that TNO performed (Horst et al., 2007), long term digital video recordings have been made at four urban intersections for a period between 19 and 22 months. It was concluded that studying traffic conflicts and deviant behaviour in this way gives a good insight in potential safety problems at specific locations from a road user's perspective, including vulnerable road users like bicyclists and pedestrians.

In a naturalistic driving observation study vehicles are equipped with observation equipment to study natural driver behaviour behind the wheel of their own car. This allows the researcher to study continuous vehicle data like speed and accelerations. The cameras mounted allow the research to have an insightful look into what's happening in and around the vehicle. It allows within-subjects comparisons of driving behaviour over a series of situations. In the case of larger numbers, between-subjects comparisons are also possible.

In the in-vehicle observation approach detailed information can be gathered from the driver and the vehicle, but information about vulnerable road users is limited. In a site-based observation study, a particular site is equipped with video cameras that continuously record the traffic flow. This allows the traffic flow and the interaction between the different road users to be observed. The bird's eye view provides a good overview of a

site. Data gathered from site-based observations allow between subject comparisons of road user behaviour. This may complement in-vehicle studies by being able to observe all the traffic including vulnerable road users such as bicyclists and pedestrians.

1.3 Focus of the study: Intersections and cyclists

The Dutch field trial focussed on driving behaviour at intersections and in particular the interaction between cyclists and vehicles. This is a relevant subject to study as in the Netherlands cycling is a very common means of transport. In terms of traffic safety there is still a lot to gain. There are around 180 fatalities and 7000 hospitalizations amongst cyclists a year in the Netherlands. For 58 % of the casualties, a vehicle is the crash opponent of the cyclist, 79% of cyclist casualties are in urban areas and 67 % of cyclist casualties in urban areas are at intersections.

For the site-based observations one intersection was selected to study. For the in-vehicle observations, participants were recruited who cross this particular intersection, as well as six other intersections, on a regular basis. All intersections were signalised. This overlapping study design is illustrated in Figure 1. The figure shows that a continuous flow of traffic is observed in the site-based observation and that one vehicle is observed at different intersections in the in-vehicle study. The central intersection in the figure indicated the overlapping measures. For this intersection both the in-vehicle and the site-based observations are made.

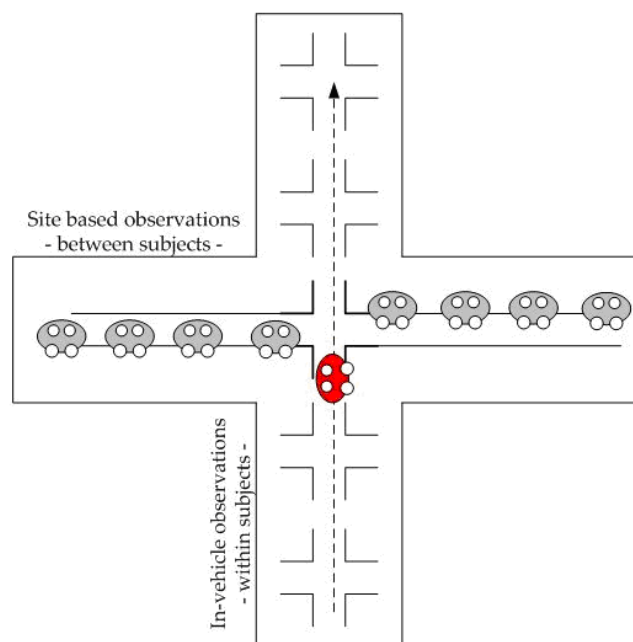

Figure 1. Illustration of relation between site-based observation and in-vehicle observation.

The focus of the Dutch field trial is on this overlapping data. This will be studied in depth to assess the feasibility and added value of combining site-based and in-vehicle observations. This overlapping data allows us to study behaviour using the two complementary perspectives. Also, this overlapping data allows us to validate measures from one study with the other.

Combining information from the site-based and the in-vehicle observation could considerably enhance the understanding of events, like road user interaction. For the purpose of this study, one particular event was selected. This is the possible conflict be-

tween a vehicle and a cyclist when a cyclist goes straight at the intersection and the vehicle is turning right.

1.4 Objectives of the study

The objective of this study is to explore the value and feasibility of combining two observation methods, site-based observation and in-vehicle observation. The value of the combining the two methods is twofold. At first it offers the opportunity to enrich the information from one study with complementary observations from the other study. Secondly, it offers the opportunity to *validate* measures from the individual studies.

For the combined study two objectives have been defined:

1. To study interaction between car drivers turning right and cyclists going straight
2. Compare speed measure from site-based study and in-vehicle study (validation)

The site-based study in itself also had the objective of exploring technical analysis procedures. Specifically the comparison of automatic and manual processing of the video data.

1.5 Study design

This study focussed on interaction between cyclists and vehicles on a traffic light controlled intersection that allows potential conflicts for right turning vehicles. A potential conflict is defined as the situation where the traffic light control allows the paths of the cyclists and vehicles to be crossed. On the observed intersection, a potential conflict exists when a vehicle is making a right turn. Both vehicle and cyclist receive a green light at the same time. A vehicle making the right turn crosses the path of a cyclist moving straight ahead. An illustration of the situation is given in Figure 2.

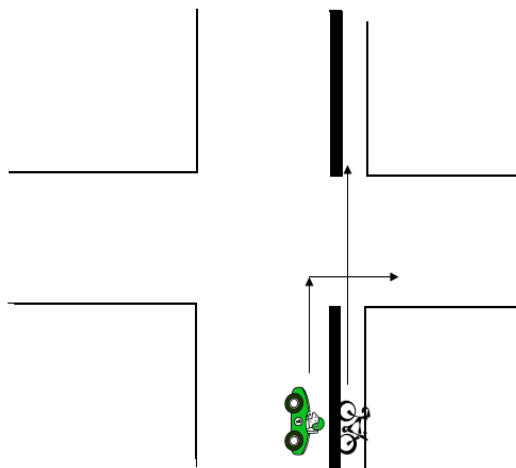

Figure 2. Illustration of potential conflict between vehicle and cyclist

1.5.1 Conditions

The behaviour of drivers is studied for different situations with respect to the phase of the traffic light and the presence of cyclists.

Phase of traffic light

For the right turn manoeuvre, two different situations can be distinguished:

- a) the vehicle had to wait for the traffic light and starts the right turn manoeuvre from a halted situation,
- b) the vehicle had a green traffic light when approaching the intersection and makes the right turn manoeuvre from a non-halted situation.

Differences in driving behaviour and interaction with cyclists can be expected between these two situations. In the non-halted situation for example, the driver might have a better mental image of the presence of cyclists at the intersection, because while approaching the intersections the entire intersection can be overlooked. In addition, the time between having the entire overview on the intersection and making the right turn is shorter and thus fewer changes are to be expected. In the halted situation, the mental image of other road users on the intersection might be less accurate. From the position where the vehicle has to wait for the traffic light, not the entire intersection can be easily overlooked. To compensate for this effect, differences in glance and speed behaviour could be expected.

The automatic video detection of road users by video processing is based on detecting moving objects with respect to a fixed background, vehicles that stand still, i.e. a speed of 0 km/h, are not detected. Therefore, for this type of analysis we adjusted the definition of a halted vehicle to a low speed (below 20 km/h), as vehicles that stopped for a red light and just accelerated to take a right turn. These vehicles were counted as vehicles that made a right turn from a halted position.

Presence of cyclists

The presence of cyclists is also likely to influence speed and glance behaviour. The presence of a cyclist, who could potentially be on a conflicting path with a vehicle making a right turn, might result in differences in driving behaviour of the vehicle. The presence of a cyclist might invoke increased glance behaviour of the vehicle driver to keep track of the cyclist's moves and avoid a conflict. Also speeds are likely to be lower.

The four conditions described lead to a 2x2 research design as illustrated in Table 1. To study possible differences in driving behaviour between the four conditions, data from both the in-vehicle and the site-based observation were used. An overview of the dependent variables from both the in-vehicle and the site-based observation is given in Table 1. Further operationalisation of the study design and its dependent and independent variables is described in Chapter 3 on methodology.

Table 1. 2x2 research design and dependent variables of the in-vehicle and site-based observations

	Halted situation	Non-halted situation
Cyclist present	In-vehicle variables: – Glance behaviour – Speed – Accelerations (longitudinal, lateral)	In-vehicle variables: – Glance behaviour – Speed – Accelerations (longitudinal, lateral)
	Site-based variables: – Speed – Time to Collision (TTC) – Post Encroachment Time (PET)	Site-based variables: – Speed – Time to Collision (TTC) – Post Encroachment Time (PET)
No cyclist present	In-vehicle variables: – Glance behaviour – Speed – Accelerations (longitudinal, lateral)	In-vehicle variables: – Glance behaviour – Speed – Accelerations (longitudinal, lateral)
	Site-based variables: – Speed	Site-based variables: – Speed

1.5.2 Hypotheses

Based on the dependent variables as described in Table 1, the following hypotheses for the halted versus non-halted conditions have been postulated.

Phase of traffic light

Vehicle drivers might have a less accurate mental image of the presence of other (vulnerable) road users on the intersection from the halted situation compared to the non-halted situation; it is assumed that the behaviour will be adapted to take safety measures. Therefore it is hypothesized that:

In the halted situation compared to the non-halted situation (as illustrated in Table 2), the glance behaviour will increase, the speed will decrease and the accelerations will decrease.

Table 2 Halted situation compared to non-halted situation.

Halted	Non-halted
↑ Glance behaviour	↓ Glance behaviour
↓ Speed	↑ Speed
↓ Accelerations (longitudinal, lateral)	↑ Accelerations (longitudinal, lateral)
↑ TTC	↓ TTC
↑ PET	↓ PET

Presence of cyclists

Vehicle drivers will adapt their driving behaviour to avoid a conflict with a cyclist. Therefore it is hypothesized that:

When cyclists are present compared to no cyclist present (as illustrated in Table 3), it is expected that the glance behaviour will increase, the speed will decrease and the accelerations will decrease.

Table 3 Cyclist present compared to no cyclist present.

Cyclist	↑ Glance behaviour ↓ Speed ↓ Accelerations (longitudinal, lateral)
No cyclist	↓ Glance behaviour ↑ Speed ↑ Accelerations (longitudinal, lateral)

Overall extreme cases (as illustrated in Table 4):

When there is a cyclist present and the vehicle driver starts the right turn manoeuvre from a halted situation compared to the situation where there is no cyclist present and the vehicle driver starts the right turn manoeuvre from a non-halted situation, it is expected that the glance behaviour will increase, the speed will decrease and the accelerations will decrease.

Table 4 Overall extreme cases (non-hatched cells): cyclist present in halted situation compared to no cyclist present in non-halted situation

	Halted	Non-halted
Cyclist	↑ Glance behaviour ↓ Speed ↓ Accelerations (longitudinal, lateral)	
No cyclist		↓ Glance behaviour ↑ Speed ↑ Accelerations (longitudinal, lateral)

2 Technology used

This chapter describes the technology used in this study. First the technology for the site-based observation is described and then the technology used in the in-vehicle study.

2.1 Site-based observation

For the site-based observation one intersection in an urban area in the village of Zeist was equipped with two cameras. We chose this specific intersection because it is equipped with a so-called full lens. This means that traffic going straight (vehicles and bicycles) and traffic going right have a green light at the same moment. Also this intersection is near to where the participants of the in-vehicle observation work, so they pass this intersection regularly. Both cameras were installed on the same lamp post the location of which is indicated in Figure 3. Figure 4 shows the two cameras.



Figure 3. Picture of the intersection in the village of Zeist. The white dot indicates the location of the cameras.



Figure 4. Photos of the two cameras in the lamp post.

The two cameras were positioned with a different angle. In this way the two provide a broader picture of the area of interest, which can be seen in Figure 5. The left picture show the traffic light where the vehicles that we focus on take a right turn, while the bicycles drive straight ahead at the same moment in time.



Figure 5. Views of both cameras.

Within the site-based observation study we compared two ways of video analysis: Manual (image based) and Automatic (video based) processing. Both digital camera's stored the traffic scene by means of jpeg images of 12.5 HZ (for manual processing) and by means of avi movie (for automatic processing). The technologies used for each type of processing are described below.

TNO rented the equipment needed for the site-based observation for two weeks. Including installation and de-installation, the costs were 6.000 Euros.

2.1.1 Manual processing

For the manual processing the stored video images are viewed by a human observer, who stores the time and position of each vehicle and bicycle using the TNO software tool CarTracker. In this way the numbers of vehicles and bicycles are counted, and their trajectories are plotted by following their position in time. A screen shot of the software is shown in Figure 6. *Encounters* or potential conflicts are counted separately on the cross intersection between a car taking a right turn and cyclist crossing the intersection. The following definition of a potential conflict is used:

“When a car is taking a right turn on the cross intersection a potential conflict occurs when a cyclist is cycling near the traffic light on the cyclist path to cross the intersection. An illustration is shown in Figure 2.

It's possible that one car or cyclist has more encounters with other road users. All counted encounters in the specified time span are written into an excel sheet with time and type of encounter included.

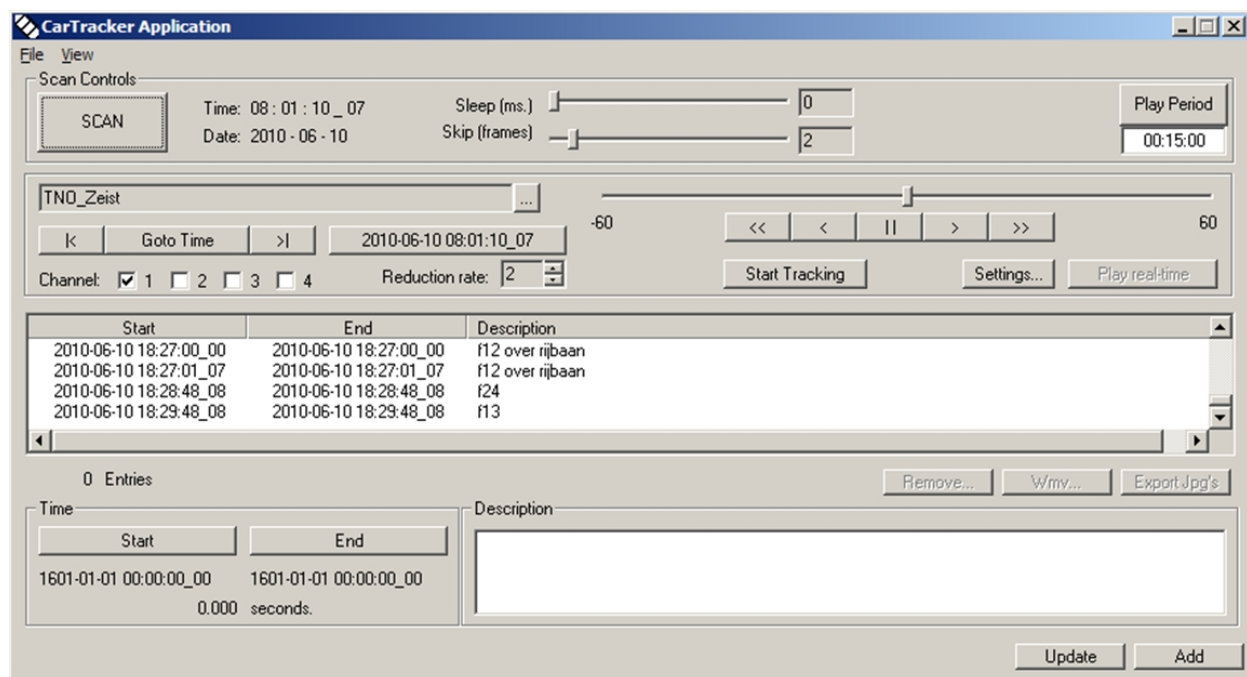

Figure 6. Screen shot of the TNO CarTracker software tool.

After using the CarTracker software for basic storage, the software package MATLAB (R2007b) is used to analyse the data.

2.1.2 Automatic processing

The avi movie of the traffic scenes had a frame rate of 15 frames per second. The video data were divided into several avi-files of 15 minutes.

The software package MATLAB was used to process the video data. Furthermore some toolboxes, which are developed by TNO were used. These toolboxes were:

- | | |
|-----------------|--|
| ARGOS-SDK | developed for live processing; this toolbox was used for object detection |
| Tracker toolbox | for tracking of the objects after detection |
| VBM toolbox | Part of this toolbox is used to calibrate the image. The calibration was used for transforming detections from image coordinates to world coordinates. |

For the processing a High Performance Cluster is used. This cluster has 200 computer nodes. With this cluster it was possible to analyse one week's video within one day.

2.2 In-vehicle observation

For the in-vehicle observation, off-the-shelf equipment was used. The data acquisition system (DAS) used in this trial is known as the *pdrive system*, developed by Race Technology Ltd. The *pdrive system* has been used and further developed for over a decade, mostly in driver training environments. For this experiment a total of eight data acquisition systems were leased from Test and Training International (TTI) for the duration of the trial. A detailed description of the soft- and hardware changes made to the *pdrive system* specifically for the PROLOGUE trial is given in D3.3 (Gatscha, Brandstätter & Pripfl, 2010) in the next paragraph a description of the system is given as it

was used in this trial. The total purchase price of one DAS, with the peripherals as used in this trial, would be around €2500-€3000.

2.2.1 Description of the Data Acquisition System

The Data Acquisition System (DAS) consists of a main unit and several (optional) peripherals (Figure 7). The main unit is the central data processing system where all data from internal and external sensors are (pre)processed and stored. The main unit contains a Compact Flash card slot for data storage. In this trial a 32 gigabyte Compact Flash card was used. The DAS is powered either by the internal battery pack or by connecting an external (12 volts) power supply. In this trial the DAS was (permanently) powered by the vehicle's (starter) battery.

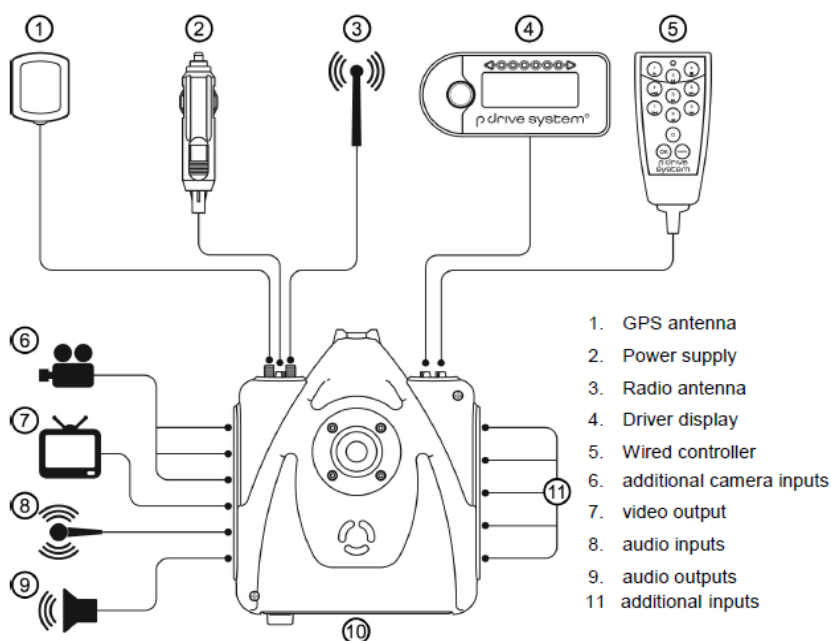

Figure 7. Overview of the pdrive data acquisition system

The DAS is capable of recording data from numerous internal and external sensors including video data from multiple cameras. An overview of optional sensors is given in Table 5.

In the Dutch in-vehicle trial the following was recorded: video data, GPS data (and GPS derived variables like speed) and acceleration data (XYZ-axis). An overview of the variables recorded is provided in Table 6.

Table 5 Overview of sensors that can potentially be used with the pdrive data acquisition system.

Variable	Description	Technical specification
Video data	DVD quality, one camera on main unit, 4 external camera connections	PAL, DVD quality, 25 fps, 2-8Mb/s, picture-in-picture(PIP) recording when multiple camera's attached
Audio data	internal or external microphone	48 KHz, Stereo
GPS data	with (wired) external GPS antenna	20 Hz position and speed updates
Accelerometer	Sensor in main unit	XYZ-axis, up to 1,8g, 100 Hz
8 analogue inputs	for external sensors, e.g. temperature sensor	Up to 100 Hz
2 serial inputs	for external sensors/connections, e.g. connection to the vehicle's ECU interfaces	Up to 115,2 k baud
Event markers	User generated by wired controller or by radio controller	

Table 6 Overview of variables recorded in the Dutch in-vehicle trial.

Variable	Technical specification
Video data	Two external cameras. Camera facing driver (black and white), forward facing camera (colour). PAL, DVD quality, 25 fps, 8Mb/s, picture-in-picture (PIP) recording. No audio. Event triggered recording of video data.
GPS data	20 Hz position and speed updates. Continuous recording.
Accelerometer	XYZ-axis, 100 Hz. Continuous recording.

For the video data, two external cameras have been used: one (black and white, low light sensitive) camera facing the driver, and one forward facing (colour) camera. An illustration of the video data and the camera setup is given in respectively Figure 8 and Figure 9. Video data was only recorded for specific events, while GPS and acceleration data were recorded continuously.



Figure 8. Illustration of recorded video data.



Figure 9. Illustration of camera setup

An event could be described as an occasion where one of the recorded variables exceeds a predefined threshold. The DAS is capable of recording and storing video data up to ten minutes before the predefined threshold. To do so, the DAS continuously stores video data in its internal memory (10 minute video data capacity, once it is full, it overwrites the oldest data) and only writes it to the Compact Flash card if an event occurs. In this trial several events were defined:

- *Location event*, a two minute video clip was recorded when the driver was at a predefined geographical location. The driver's geographical location was determined by the GPS data.
- *Identification event*, after the first minute of the trip a one minute video clip was recorded. This event (always the first event) was used to identify the driver and check if this is the participant (data will be analysed) or whether it is an occasional driver (data will not be analysed).
- *High longitudinal acceleration*, a three minute video clip was recorded when longitudinal acceleration exceeding (+/-) 6 m/s/s was detected. The recording covered two minutes before exceeding the threshold and one minute after exceeding the threshold.
- *High lateral acceleration*, a three minute video clip was recorded when lateral acceleration exceeding (+/-) 6 m/s/s was detected. The recording covered two minutes before exceeding the threshold and one minute after exceeding the threshold.
- *Speeding*, a three minute video clip was recorded when speeds exceeding 150 km/h were detected. The recording covered two minutes before exceeding the threshold and one minute after exceeding the threshold.

The *location event* was the crucial event for analysing the glance behaviour at intersections. In this trial, 32 *location events* were defined at eight predefined intersections. One of these intersections was also observed with site-based observation equipment. The *high longitudinal or lateral acceleration and speeding* events were included for ex-

plorative reasons. This allowed information to be captured in case of a (near) crash or extreme driving behaviour.

A *location event* was triggered when the vehicle passed a predefined geographical location travelling in a predefined direction. This trigger, called a *location event trigger*, can be seen as a line on a map. When this line is crossed in a predefined direction, the location event is triggered. Figure 10 shows such *location event triggers* on an intersection. The (blue) lines are the *location event triggers*, the arrows indicate the direction. When a car crosses a *location event trigger* in the direction of the arrow, in this case leaving the intersection, two minutes of video data were recorded before passing this geographical location. To capture the event of crossing an intersection from all possible directions, four *location event triggers* were defined for each intersection. This resulted in 32 *location event triggers* for the eight observed intersections. In order to specify the location event triggers, a trip had to be made with the DAS recording GPS data in the geographical location and travelling in the desired direction. Based on the data of this trip, location based event triggers could be defined. This resulted in a 'location based event trigger'-file that could be uploaded to the DAS.

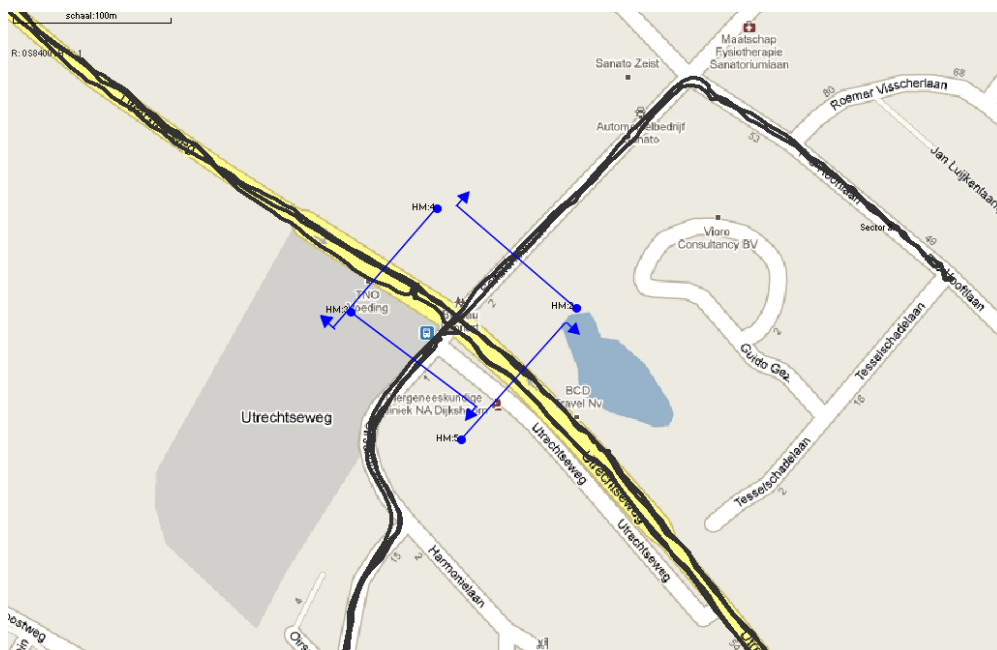

Figure 10. Illustration of location based event triggers

Operating modes of the Data Acquisition System

The DAS can operate in different modes (Figure 11). The different modes allow the DAS to record data when the vehicle is moving, and save power when the vehicle is idle. In this paragraph, the different operating modes and the way it switches between these modes are described.

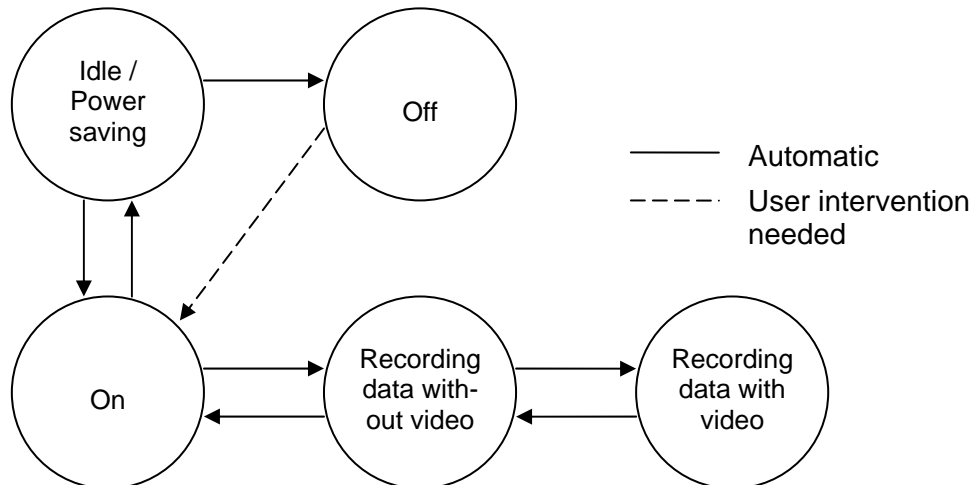

Figure 11. Overview of different operating modes of the Data Acquisition System

To start with, the DAS can be switched *off*. In this mode, no power is used. A user intervention, pressing a button, is needed to turn the DAS to the ‘*on*’ mode.

In the *idle/power saving* mode, the DAS will automatically turn *on* when movement is detected by the internal accelerometer. If no movement is detected for a predefined period of time (in this trial three days), the DAS will turn *off* to prevent depleted batteries. When the DAS is turned off, as described above, user intervention is needed to turn the DAS on again.

When the DAS is turned *on*, the DAS doesn’t immediately start recording. The DAS starts recording vehicle data (all variables except video data) only if a predefined criteria is fulfilled. The DAS was set to start recording data when the (GPS) speed was more than 5 km/h for more than one second. The DAS was set to go back to the first stage of the *on* mode, when no movement (GPS speed < 8 km/h) was detected for five minutes. The DAS would then stop recording data. From the *on* mode, the DAS was set to go back to *idle/power saving* mode again when no movement (GPS speed > 5km/h) was detected for more than two minutes.

If during the *recording of data without video* an event occurred, video data was stored for the duration as defined in the event.

2.2.2 Recorded data structure and format

The DAS records the data from all the sensors in a proprietary format. Video data is always stored in a separate file. The DAS stores all data following a specific file/folder structure. An illustration of this structure is given in Figure 12. For each date when trips have been recorded, a folder was created (date folder). In that folder, for each trip that has been recorded on that specific date, a new folder was created (trip folder). In the trip folder, the data file is stored containing all data from all sensors for that trip. If, during that specific trip, a predefined event had occurred, an event folder was created. In the event folder, two files were created; a video file containing video data for that specific event and a data file containing the data from all sensors during the specific event.

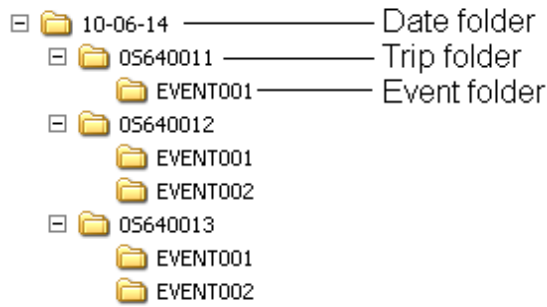

Figure 12. Illustration of file and folder structure of data recorded by the DAS.

The data file can only be opened using the analysis software included with the pdrive system. The analysis software (Figure 13) can, amongst other functions, plot the trip on a map, show graphs and figures for the sensory data and play the recorded video segments. The analysis software can also convert the data to comma-separated-values (CSV) or to the 'Matlab' format. This allows the data to be analysed with a whole range of commonly used (statistical) software. The video data can be viewed with any MPEG2 capable video player.

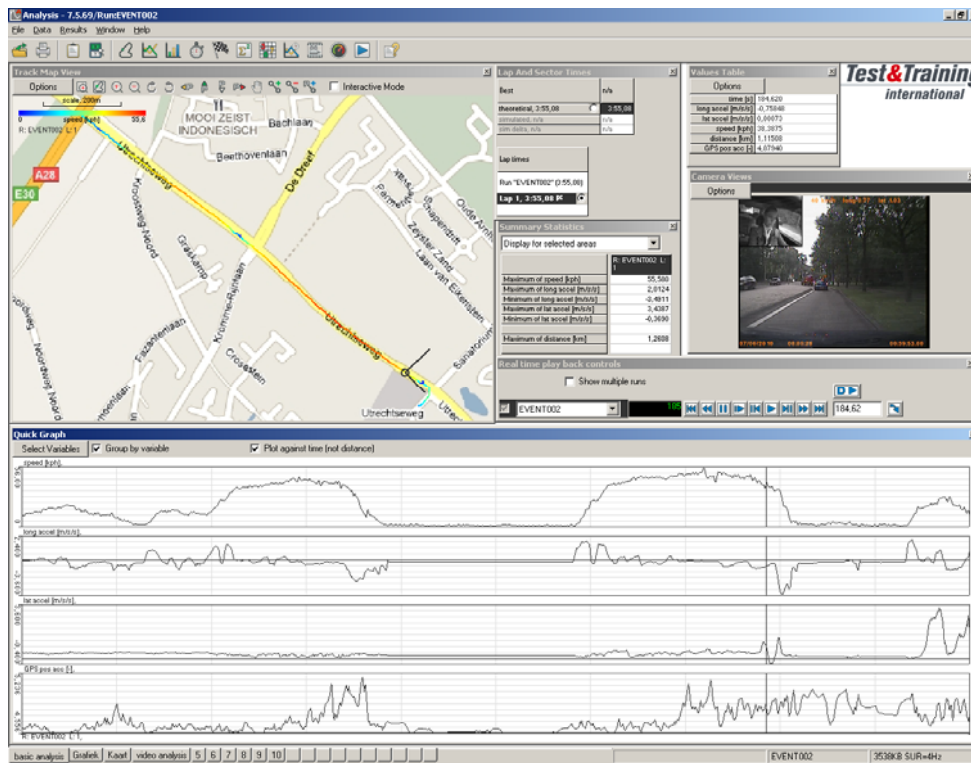

Figure 13. Illustration of the analysis software

3 Methodology

This chapter describes the methodology used in this study. The methodology for the site-based observation is described first, followed by the methodology for the in-vehicle study.

3.1 Site-based observation

The gathered data (video and images) of the site-based observation are divided into two studies for further analyses: Manual (image based) and Automatic (video based) processing of the passing cars and bicyclists.

By analysing the same traffic with the two methods we can compare the results and discuss the pro's and con's of each type of analysis.

With both methods we aim to establish the following:

1. Number of cars and bicyclists
2. Speed profile of the cars turning right
3. Post Encroachment Time (PET) of the cars and bicyclists passing the same conflict zone.
4. Time To Collision (TTC) in case of a possible predicted collision.

3.1.1 Manual processing

In this subsection the procedures and methods are described to process the captured images of the site-based observation.

Data

The site-based cameras stored the video images of two full weeks. Because this study is aimed at investigating the possibilities of this type of data recording and analysis, we chose one day (at random) to analyse. This was Tuesday June 8th, 2010 in a time span from 06 AM until 08 PM. In this specified time span 567.721 images have been captured. This is less than expected with a camera capture rate of 12.5 Hz and can be explained by the fact that the camera only captures images when there's movement detected.

Step 1: Counting of road users

From the captured images all road users have been counted and written into an excel file with the following information:

- start time
- type of road user including pedestrians
- direction of road user

Step 2: Tracking of road users

To determine the size of the road user and velocity, the exact location of a road user has to be tracked per image. Using CarTracker the captured images can be imported and a road user can be tracked by selecting the centre of the visible wheels. This stores the corresponding pixel points, time, and comments (like type of road user and direction) in a dat-file as shown in Figure 14.

Tracking is performed on cars and cyclists of interest every 3rd time frame, which is 0.24 [s]. To compare the site-based observation with the in-vehicle observation, the specific cars with in-vehicle equipment are tracked each time frame, 0.08 [s].

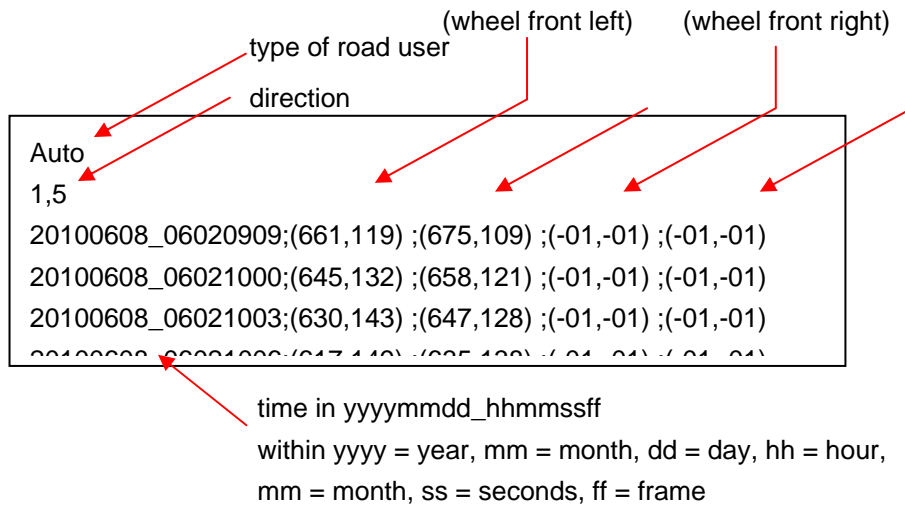

Figure 14. Dat-file output of CarTracker.

Step 3: Coordinate transformation

The tracked data using CarTracker is stored in pixel coordinates. These pixel coordinates have to be transformed into world coordinates (meters). Therefore various points in the camera frame are selected, as shown in Figure 15, to retrieve the corresponding pixels. Second, the same points are selected in Google maps to retrieve the GPS coordinates, as shown in Figure 16. To convert geodetic coordinates into Earth Centred Earth Fixed (ECEF) (world) coordinates a method is used as described on http://en.wikipedia.org/wiki/Geodetic_system.

The world coordinates of the selected points are shown in Figure 17. An overview of the points in pixel, geodetic and world coordinates are shown in Table 7.

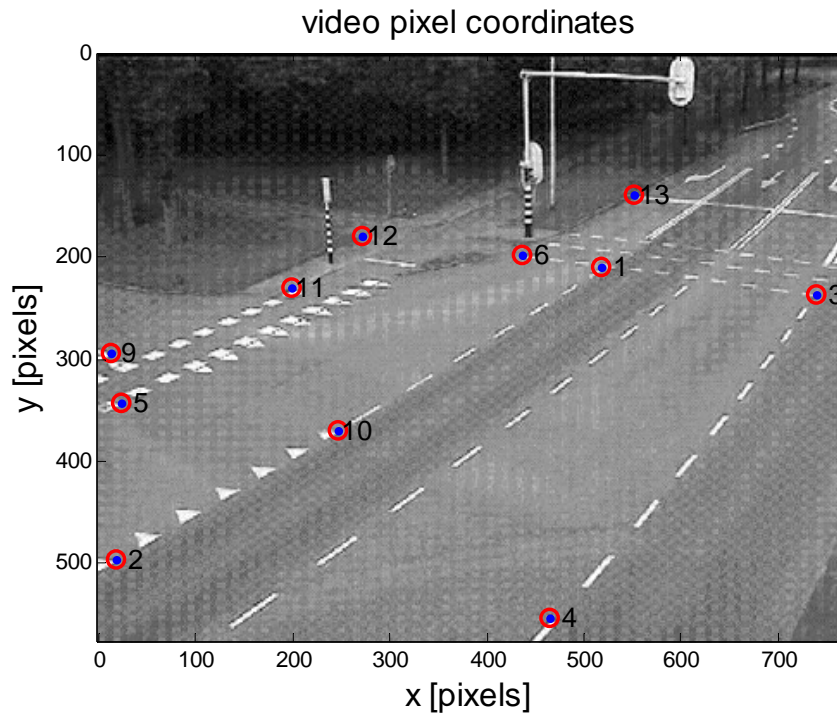

Figure 15. Coordinate transformation, video pixels

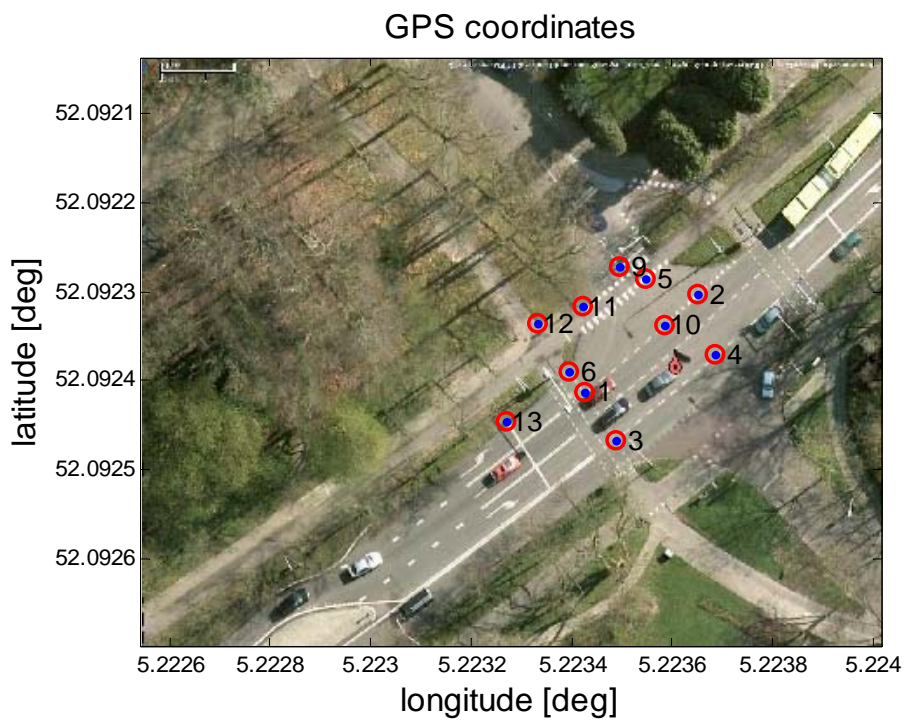

Figure 16. Coordinate transformation, GPS

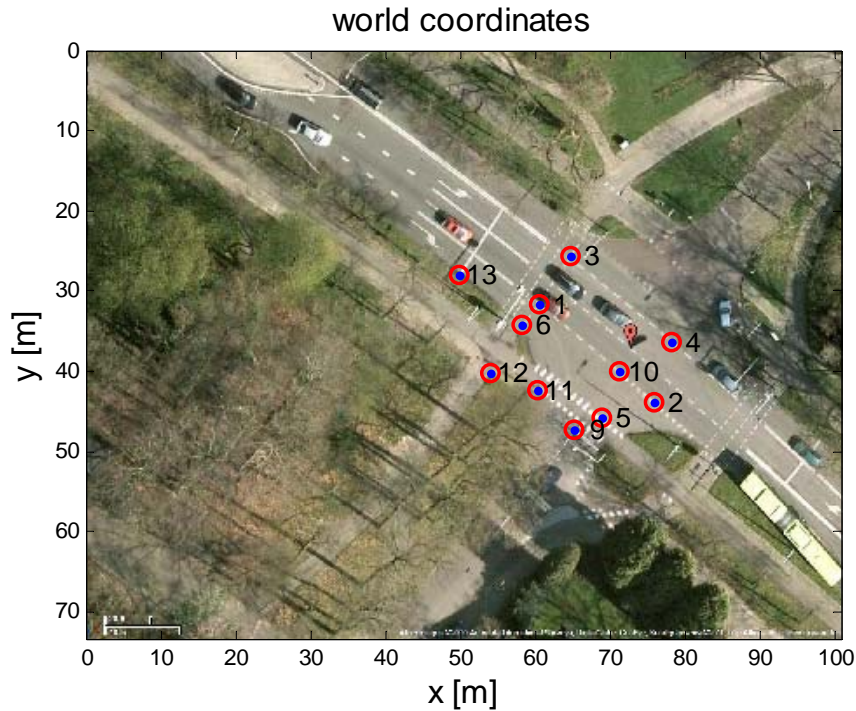

Figure 17. Coordinate transformation, world

Table 7. Points used for coordinate transformation

points	lat [deg]	lon [deg]	xr [m]	yr [m]	xv [px]	yv [px]
1	52,092412	5,223427	60,449200	31,711162	518	210
2	52,092303	5,223651	75,801562	43,839221	18	496
3	52,092467	5,223488	64,629847	25,591341	739	237
4	52,092370	5,223685	78,131692	36,384195	465	554
5	52,092286	5,223548	68,742311	45,730888	24	342
6	52,092390	5,223394	58,187524	34,159097	437	197
9	52,092272	5,223496	65,178423	47,288695	12	294
10	52,092337	5,223585	71,278087	40,056158	246	370
11	52,092317	5,223423	60,175181	42,281675	198	230
12	52,092336	5,223333	54,006860	40,167644	271	180
13	52,092446	5,223271	49,757467	27,928151	552	138

Using these points a transformation matrix can be made to convert all tracked pixels (of various road users) of the video into world coordinates. Detailed information on how to create a transformation matrix to convert video coordinates into world coordinates can be found in van Horst (1990).

Step 4: Path of road user

To determine the path of a road user in world coordinates, the tracked pixel coordinates are transformed using the transformation matrix, see Figure 18 and Figure 19.

When tracking a road user by hand, the exact centre of the wheels is not selected. This results in an unsmooth path after transforming the pixel coordinates into world coordinates. Also, not all wheels were visible on the tracked path in which some pixel points are missing at each 3rd frame rate, which can be seen in Figure 18 and Figure 19. To correct the derived path, an interpolation is performed on the world coordinates to find missing points on the tracked path. To smooth the tracked path a 3rd-order polynomial

curve fitting is performed on the x- and y- world coordinates of the front-left and rear-left wheels with respect to the time vector. These steps are shown in Figure 20 and Figure 21 for the left wheels of a car taking a right turn on the intersection.

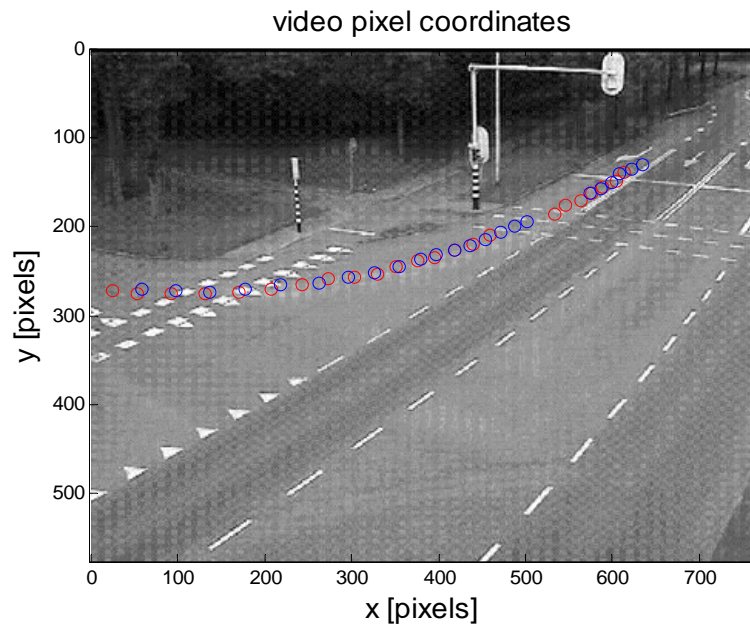

Figure 18. Path of a car taking a right turn tracked by hand by the wheels on the left side of driver.

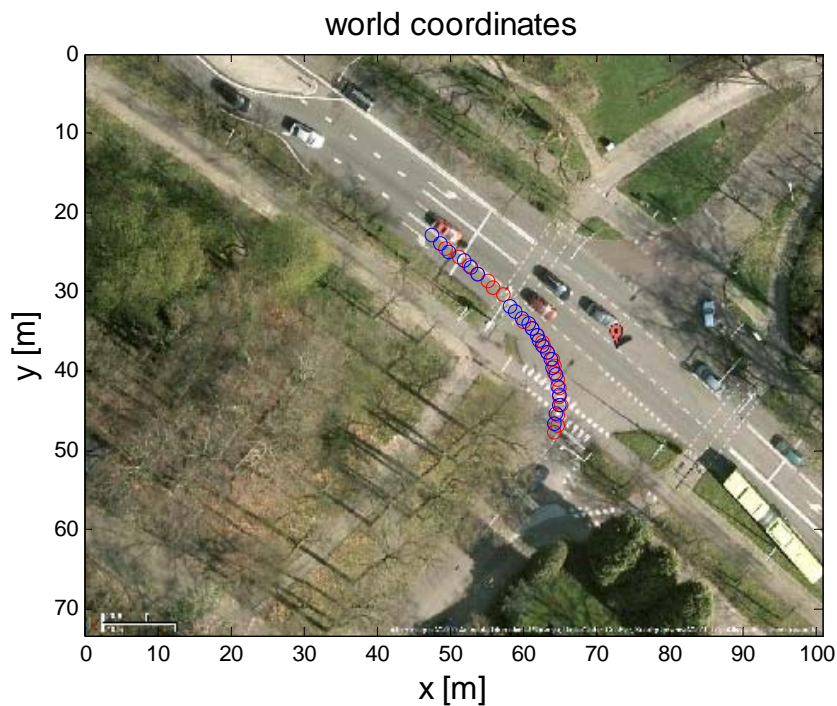

Figure 19. Path of car taking a right turn in world coordinates.

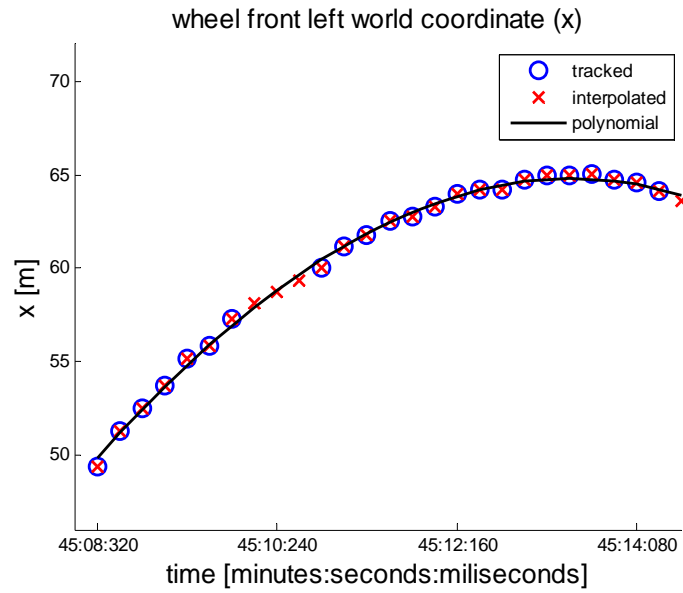

Figure 20. Tracked, interpolated and polynomial curve fit on tracked coordinates of the front left wheel of a car taking a right turn

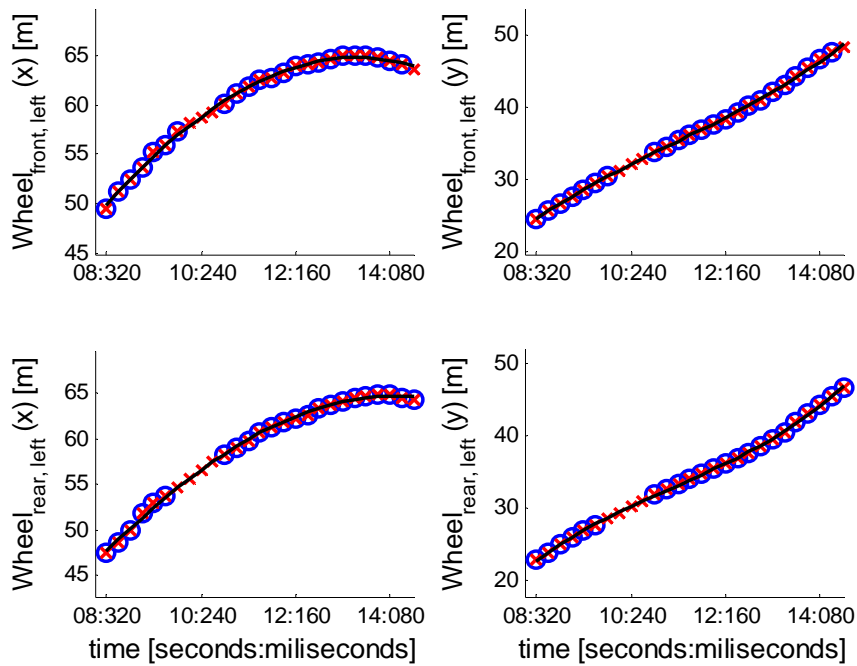

Figure 21. Tracked, interpolated and polynomial curve fit on tracked of car taking a right turn, front and rear left wheels (x- and y- world coordinates)

Step 5: Yaw angle of road user on the driven path

In order to calculate a Time To Collision of a possible near future collision between a vehicle turning right and a bicycle, we need to know the correct direction at each point in time. This is the yaw angle. To determine the yaw angle the next equation is used:

$$\psi = \arctan2\left(\frac{\text{wheel}_{\text{front,left}}(y(t)) - \text{wheel}_{\text{rear,left}}(y(t))}{\text{wheel}_{\text{front,left}}(x(t)) - \text{wheel}_{\text{rear,left}}(x(t))}\right)$$

in which $\arctan2$ is the four-quadrant inverse tangent. The result is shown in Figure 22.

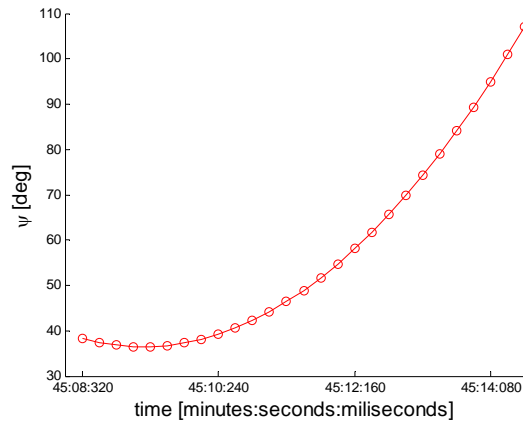

Figure 22. Yaw angle of a car taking a right turn.

Step 6: Road user size

For further analyses the size of the road user is needed. Therefore the average distance between the front and rear wheels, i.e. length of wheelbase, is determined over the tracked path. This is compared with categorized road users taken from Horst et al. (2007), as shown in Table 8, to retrieve the length and width of the road user which is used to define a bounding box as discussed in the next step.

Table 8. Size of different road users

Road user	width [cm]	length [cm]	wheelbase [cm]
Vehicle large	190	517	313
Vehicle middle	175	425	261
Vehicle small	158	354	230
Cyclist	50	180	110

Step 7: Bounding box of road user on the driven path

Now the road user measurements are known, a bounding box can be drawn around the tracked front and rear wheel. First, the centre of the bounding box is determined and using a transformation matrix the four points of the bounding box can be determined in time over the tracked path:

$$\begin{bmatrix} P_{1...4}(x,t) \\ P_{1...4}(y,t) \\ 0 \\ 1 \end{bmatrix} = \begin{bmatrix} \cos(\psi(t)) & -\sin(\psi(t)) & 0 & x_{center}(t) \\ \sin(\psi(t)) & \cos(\psi(t)) & 0 & y_{center}(t) \\ 0 & 0 & 1 & 0 \\ 0 & 0 & 0 & 1 \end{bmatrix} \begin{bmatrix} P_{1...4}(x) \\ P_{1...4}(y) \\ 0 \\ 1 \end{bmatrix}$$

Using the determined points, the bounding box can be drawn with respect to the centre of the road user, see Figure 23.

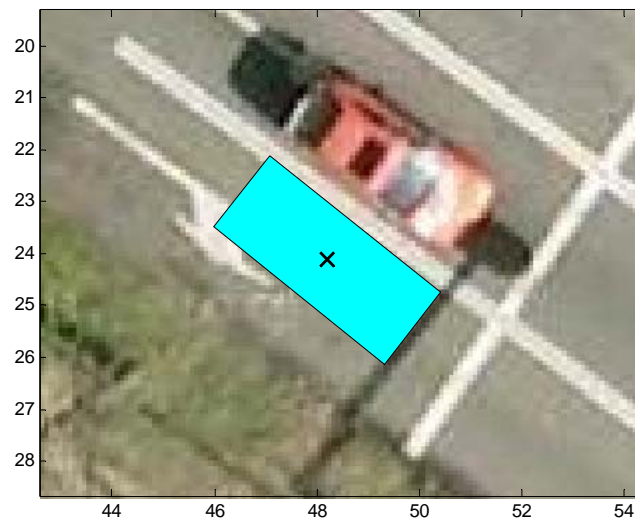

Figure 23. Bounding box around car taking a right turn

The bounding box in time over the tracked path of the car is shown in Figure 24.

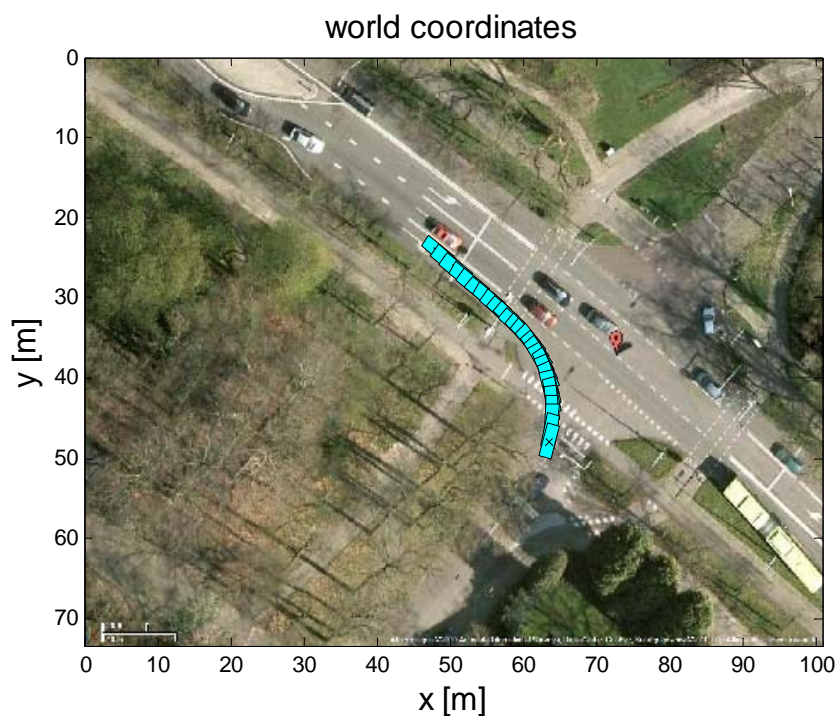

Figure 24. Bounding box of a car which is taking a right turn

Step 8: Velocity of the road users.

The velocity of the vehicles and bicycles is calculated by taking the distance of the centre of the bounding box between two time intervals divided by the difference in time, which is 0.24 s for the tracked road users and 0.08 [s] for the in-car equipped vehicles.

An interpolation on the determined velocity profile is performed to find the exact velocity profile on the measured time corresponding to the tracked path. See Figure 25.

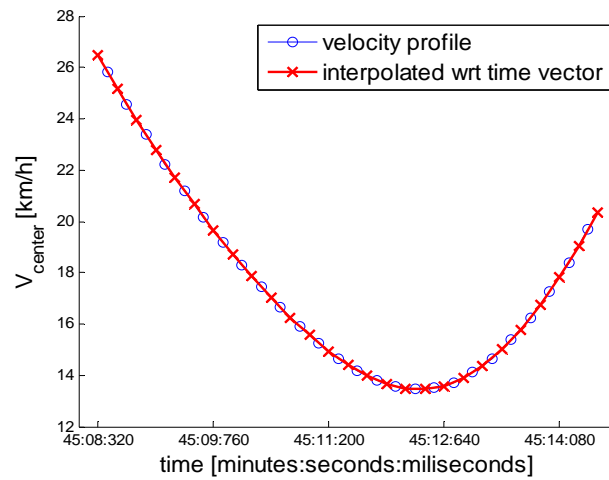

Figure 25. Velocity profile for car taking a right turn

To compare the velocity profile of the site-based observation with the in-vehicle observation, the time of the velocity profile has to be shifted. When the in-car equipped vehicle is entering the conflict area, shown in Figure 26, the time of the velocity profile has to be zero. The velocity profile with respect to the conflict area is shown in Figure 27.

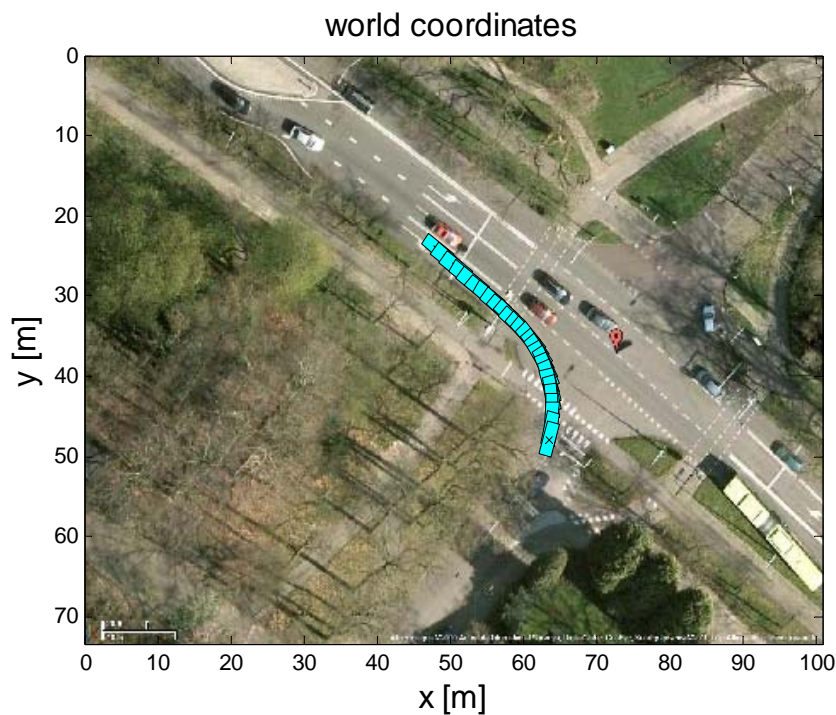

Figure 26. In-car equipped vehicle enters conflict area

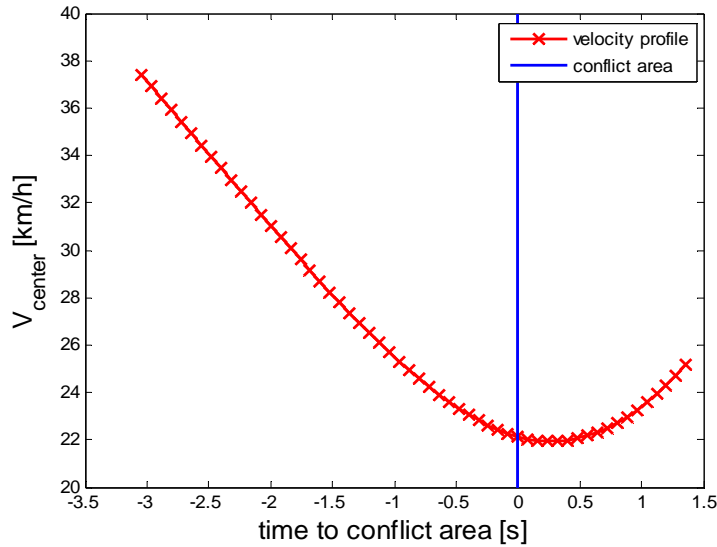

Figure 27. Velocity profile of in-car equipped vehicle wrt conflict area

Step 9: Determine halted and non-halted cars taking a right turn

For the 2x2 research design matrix cars which take a right turn on the intersection have to be divided into halted and non-halted situations. Therefore for all cars taking a right turn the velocity profile is determined. When the first four time steps of the velocity profile have values smaller than 20 km/h, the car is waiting for a red traffic light, e.g. halted situation. The definition can be expressed as:

$$\begin{aligned}
 V_{center}(t_1 \dots t_4) < 20 [km/h] &= halted \\
 V_{center}(t_1 \dots t_4) \geq 20 [km/h] &= non - halted
 \end{aligned}$$

Step 10: Post-Encroachment-Time (PET)

The PET is determined between potential conflicts of a car taking a right turn with a cyclist crossing the intersection. The PET measure is defined as the time between the moment the car leaves the path of the cyclist and the moment the cyclist reached the path of the car, or vice versa (Van der Horst, 1990). In Figure 28 this is visualised by two cars, of which car2 is approaching car1 at t_1 . At t_2 car2 reaches the point where the paths of car1 and car2 cross each other. The PET at t_1 is then defined as the time difference between t_2 and t_1 . I.e the time it takes car2 to reach the point where both paths cross.

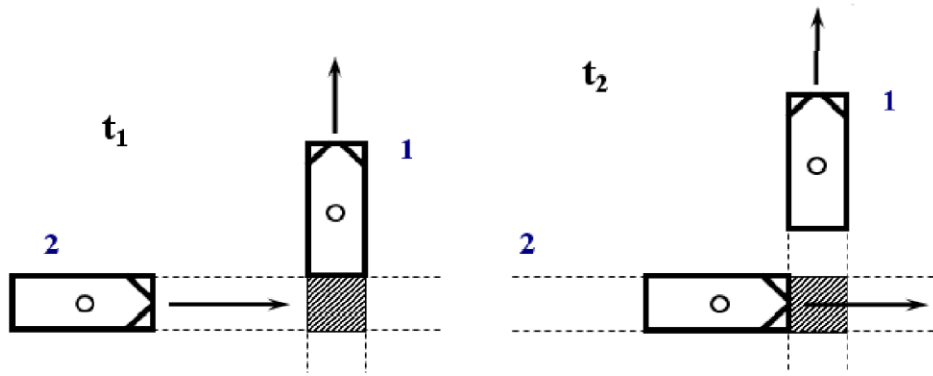

Figure 28. Visualisation of PET ($t_2 - t_1$): the time it takes car2 to reach the point where both paths cross.
From Van der Horst, (1990).

The PET is determined by showing the path (defined by bounding boxes) of a car and cyclist which are marked as a potential conflict. Using the bounding boxes of the car and cyclist, a collision can be detected by overlapping bounding boxes, using the IN-POLYGON function which detects points inside a polygonal region (bounding box).

First, a collision is detected when a bounding box of the car overlaps, 'hits', one of the bounding boxes of the cyclist as shown in Figure 29 and Figure 30. The corresponding time is T_2 . The same is performed when there's no overlap of the bounding box of the cyclist with one of the bounding boxes of the car, which means the cyclist is leaving the path of the car. The corresponding time is T_1 , by which the $PET = t_2 - t_1$.

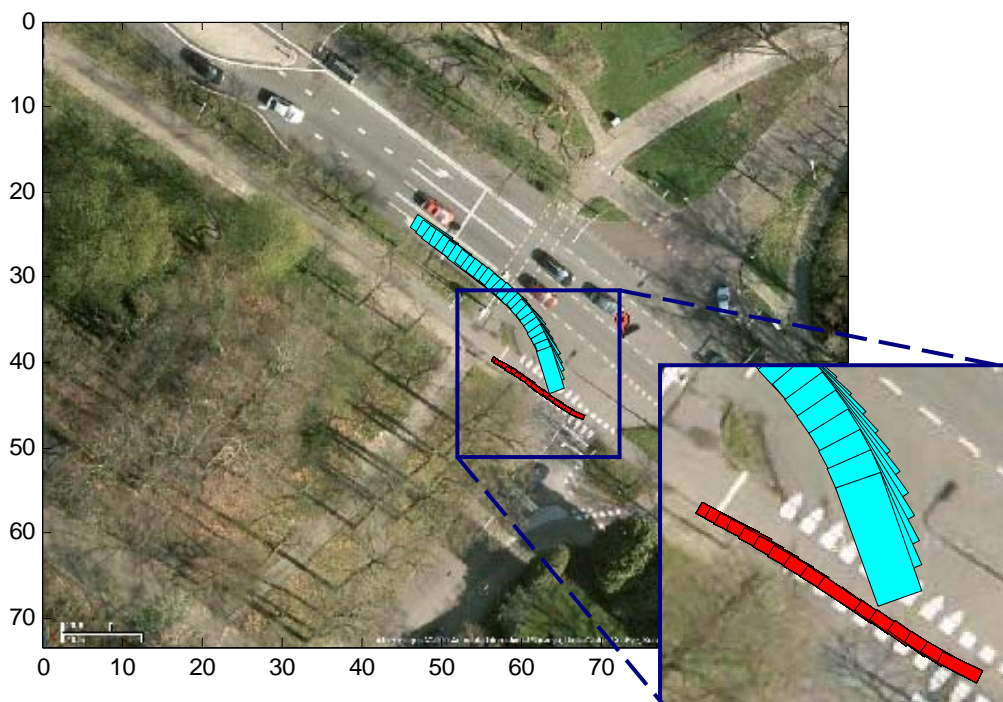

Figure 29. PET: t_2 is the moment that the car (blue boxes) enters the path of the cyclist (red boxes).

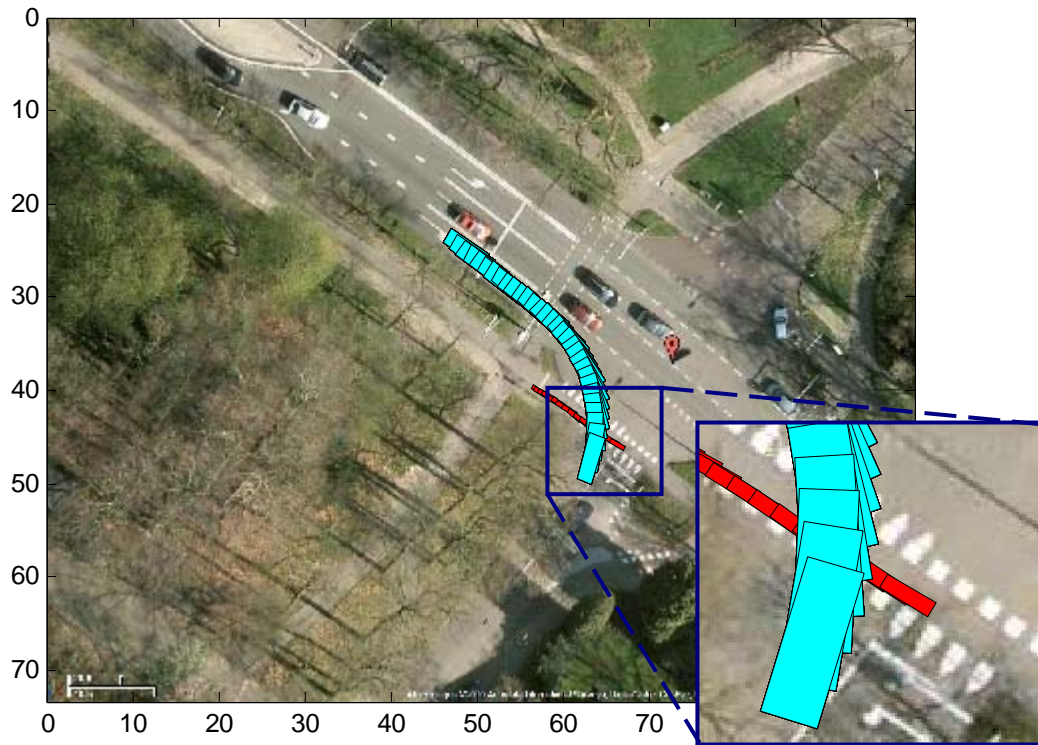

Figure 30. PET: t_1 is the moment that the cyclist (red boxes) leaves the path of the car (blue boxes).

Step 11: Time-To-Collision (TTC)

The Time-To-Collision is defined as the time that remains until a collision between two road users would have occurred if the collision course and speed difference are maintained [Hayward, 1972].

To determine a TTC of a potential conflict an extrapolation method is used to predict the path of the car and cyclist in time. First, a potential conflict is searched as shown in Figure 31. Second, the time of the car and cyclist are synchronized, which means that at a specified absolute time the location of the car and cyclist are found. This is shown in Figure 32, where the start is later on the tracked path to synchronise with the starting point of the cyclist. Each time step an extrapolation will be performed to find if a collision occurs as shown in Figure 32 and Figure 33. When an extrapolation is performed on more steps of the tracked path, it can be seen that the car is making a right turn and a collision occurs (see Figure 34). When a collision occurs on the extrapolated data a TTC can be calculated for the potential conflict.

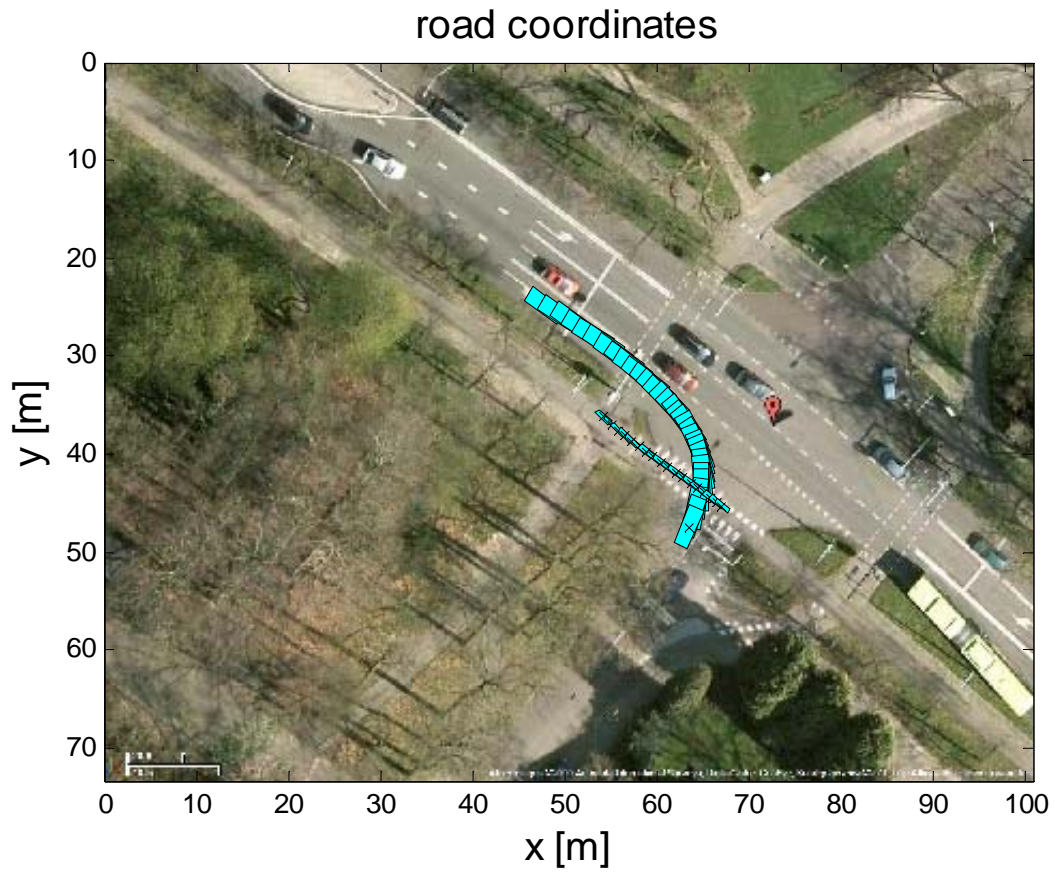

Figure 31. Potential conflict, car taking a right turn and cyclist is crossing the intersection

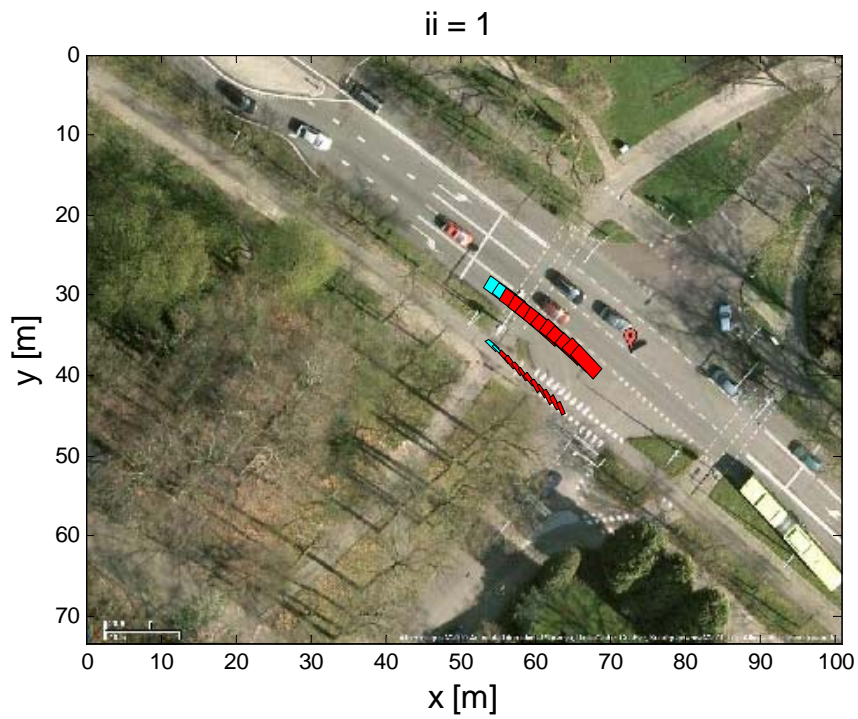

Figure 32. TTC: car and cyclist are synchronised and first extrapolation is performed

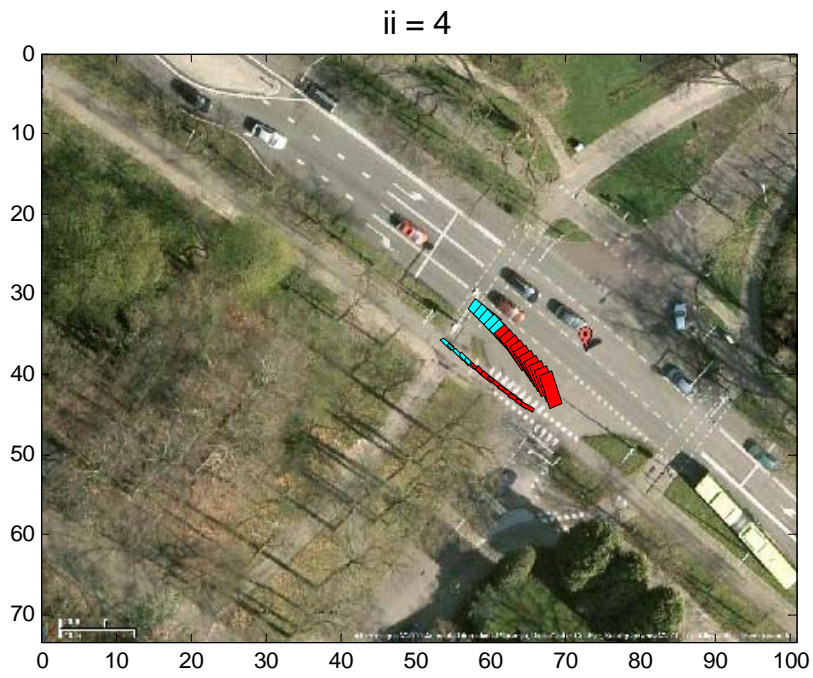

Figure 33. TTC: extrapolation is performed on more tracked data

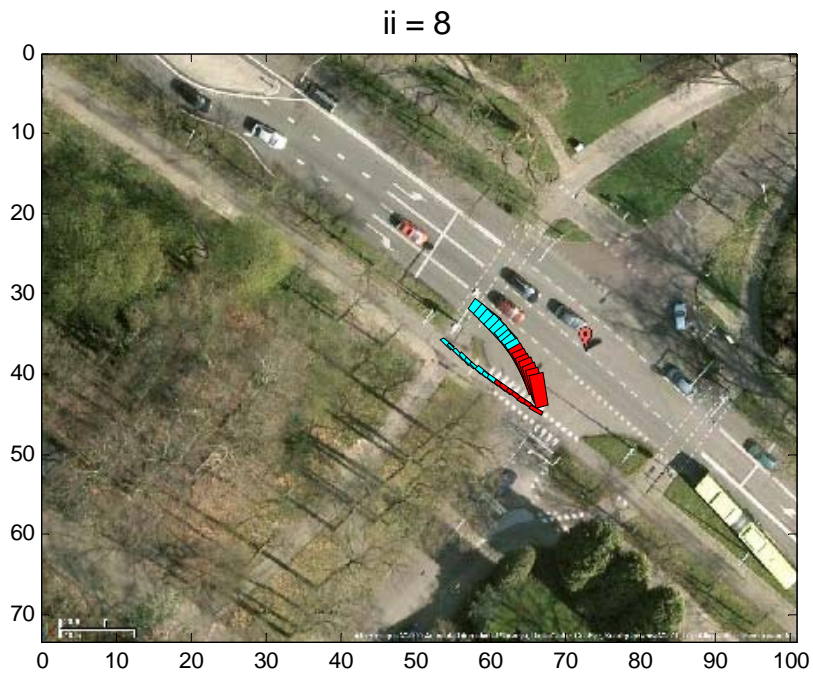

Figure 34. TTC: extrapolation is performed and a collision occurs.

3.1.2 Automatic processing

This subsection discusses the methodology of automatically analyzing the video data to decrease the throughput time of the traffic evaluation by video observation. The following measures had to be calculated automatically:

- The number of cars that turned right at a specified location at the intersection
- Of these cars that turned right, the number of vehicles that had green and red light had to be distinguished
- The number of cyclists that crossed the intersection
- The number of encounters between the cars that turned right and the cyclist that crossed the intersection. For automatic processing an encounter was defined as a vehicle turning right and a cyclist crossing the path of the in the same time period.

In general, an encounter of potential conflict for the manual processing was defined as: “When a car is taking a right turn on the cross intersection a potential conflict occurs when a cyclist is cycling near the traffic light on the cyclist path to cross the intersection.

The results from the automatic analysis will then be compared with the counting results of the manual analysis, of which the methodology was discussed in the previous subsection.

Data

The data that were used for the automatic analysis were video data of the intersection that was collected on June 8th 2010 from 6 AM to 8 PM. These video data was divided into several avi-files of 15 minutes. The avi-files had a frame rate of 25 frames per second.

Step 1

The first step was to detect the traffic that passed the intersection, which could have been cars, motorcycle, trucks, buses, cyclists, mopeds and pedestrians. The detection was based on background subtraction. First the background was estimated. Each pixel that was different from the background was assigned to a moving object, see Figure 35. These foreground pixels were merged to objects. Each object was described by a bounding box(see Figure 36). The size of this bounding box can be used to determine the type of road user, e.g. a truck or a car. This was not yet done in this analysis, because some extra filtering was needed to correct for one of the disadvantages of the used video detection technique, which is mentioned in the next paragraph.

This process has some disadvantages:

- When two or more objects have a visual overlap, these objects will be merged to one bigger object. This will give problems when trying to determine the different types of road users by considering the size of the bounding box.
- When an object becomes static, the object will be included into the background estimation. The object will disappear. When the object is moving again, there will be a ghost object at the position where it was standing still, because the background estimation differs from the real background.

Other detection algorithms like object detection by a trained detector and multi-camera tracking, which do not have these disadvantages, could not be applied to these video recordings, because more cameras at more viewpoints would be needed.



Figure 35. Left picture: Car turning right. The car is the moving object that has to be detected. Right picture: By subtracting the video frame from the background estimation, the foreground pixels will be visible (in blue), because the background remains the same.



Figure 36. The moving object, which is enclosed by the red bounding box.

Step 2

To count the number of vehicles that turned right and the number of cyclists that crossed the intersection, we need to know the path of the road user. For the determination of the path of the road users the bottom left part of the bounding box was selected as tracking point. Considering the movement of this point in time, i.e. considering the new location of this point in each video frame, results in the travelled path. Because the direction of the road user changes within the bounding box, there is an error between the real travelled path and the travelled path that was determined by video processing.

This is an error on the location of the path (which will also give an error on the speed of the vehicle). The error on the path location will be as big as the width of the vehicle as can be seen in Figure 37. The bottom left detection point on the bounding box is on the right side of the vehicle when entering the curve and is on the left side of the vehicle when leaving the curve. The use of a top view camera or multiple cameras could solve this problem.

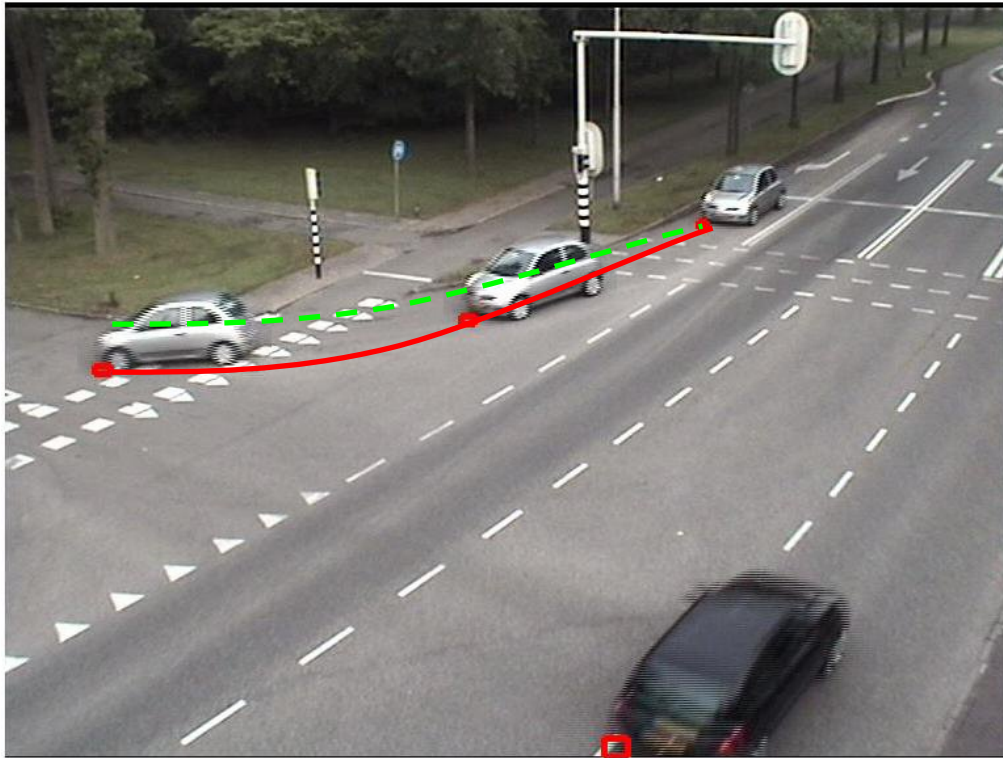

Figure 37. The tracking point of each road user was chosen to be the bottom left point of the bounding box for defining the travelled path (red line). This will give an error with respect to the real travelled path (green line).

Figure 38 shows an example of the paths for all road users that were at the intersection within a time period of 15 minutes.

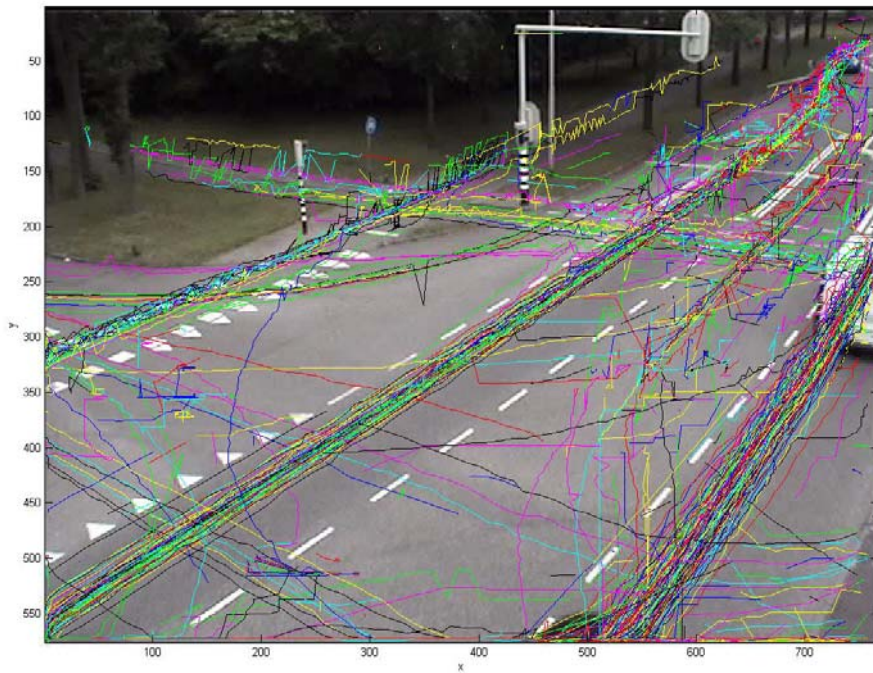

Figure 38 Examples of travelled paths of different road users.

Step 3

The detection of the moving object resulted in a location of this object in pixel coordinates. These pixel coordinates needed to be converted to earth coordinates in meters to have the distance of the road user with respect to other road users and their location on the intersection. For this conversion the distances at the intersection were measured and used for the transformation matrix (see Table 7). Figure 39 shows a top view of the paths from Figure 38 transformed to the earth coordination axes in meters. The paths that are shown in Figure 39 were also linked to the related video observation avi-files, so that by clicking one of the paths, the corresponding avi-file is shown. This was very useful to compare the results from the automatic processing with what really had happened.

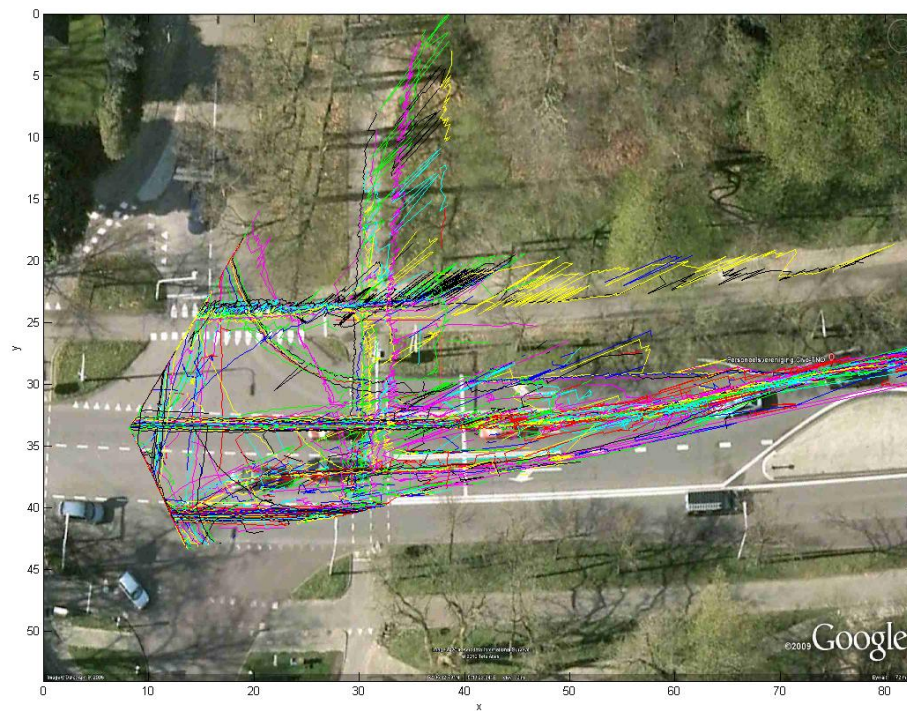

Figure 39 Examples of travelled paths of several road users converted to the earth coordination axes in meters (Background figure was taken from Google Earth).

Step 4

The direction in which the road users travelled needed to be determined. The direction of travel was considered by defining a region through which the paths of the desired direction would go. If the path of a road user crossed the defined region this road user was considered travelling in the direction of interest. An example of a region that was used to select the right turning vehicles is shown by the red square in Figure 40.

With the travelling direction information, the number of road users travelling in a certain direction was counted automatically.

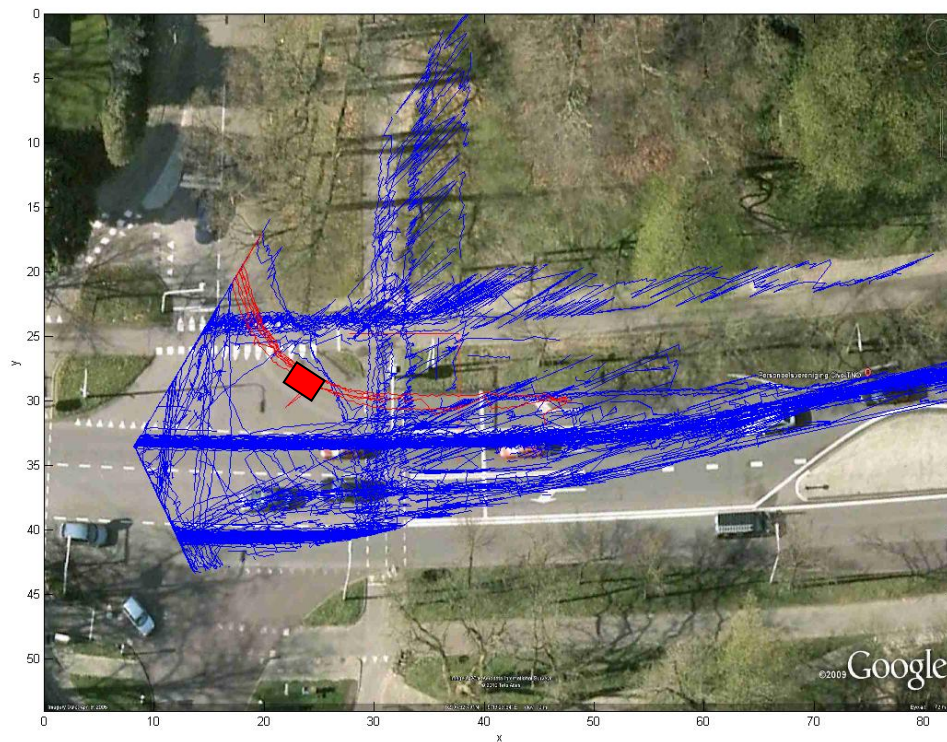

Figure 40 Selected paths (red) for vehicles that crossed the selected region (red square) and were considered as turning right at the intersection.

Step 5

The counting of vehicles that turned right and had to stop for the traffic light was done by considering the speed of these vehicles. The speed of the vehicles was calculated by looking at the change of location at every time step. This was then interpolated to a smooth speed curve. However, the speed contained a small error, because the path of the vehicles turning right could not have been well determined as was explained in Step 2.

The initial idea was to look at the speed of the vehicles in the sorting box for right turning traffic and consider the ones that had a speed of 0 km/h. These were then counted as vehicles that had to stop for a red traffic light (halted vehicles). However, because the detection of road users by video processing was based on detecting moving objects with respect to a fixed background, vehicles that stood still, i.e. a speed of 0 km/h, were not detected as was explained in Step 1. Therefore, the speed in and just after the sorting box for right turning traffic was considered. If this speed was low (below 20 km/h), it was assumed that the vehicles had stopped for a red light and just accelerated to take a right turn. These vehicles were counted as vehicles that made a right turn and had to stop for a red traffic light.

Step 6

For counting the encounters of road users also the detection time of the road users was considered. For example the counting of encounters between vehicles turning right and cyclists crossing the path of this vehicle, the detection time of both the road users was compared. If the vehicle path indicated that the vehicle turned right and the path of the

cyclist crossed the path of vehicle and they were both detected in the same time period this was defined as an encounter.

Step 7

Using the path data and adjust this for the path location error as was explained in step 2 and calculating the speed of the vehicle and the bicycle will provide the information (location and speed) that is needed to calculate the Time-To-Collision (TTC) and the Post-Encroachment Time (PET). These can be calculated using the same algorithms that were determined for the manual processing, as described in subsection 3.1.1.

3.2 In-vehicle observation

This paragraph describes the methodology for the in-vehicle observation trial.

3.2.1 Participants

Characteristics

A total of eight subjects (5 male, 3 female) participated in the in-vehicle observation trial for a period of two months. The average age of the participants was 39 years (SD=8.8, range from 28 to 51 years old). The average time the participants had their driving licence was 20 years (SD=8.9, range from 9 to 33 years) No data was recorded for one participant due to technical failures. All participants lived in the vicinity of Zeist in the Netherlands. The participants were selected to pass one particular pre-defined intersection on their route from home to work. The average distance travelled from home to work was 20 kilometres (SD=8.9). Participants who completed the trial were given an incentive of €100. All eight participants completed the trial.

Recruitment

All participants were recruited from one company. A recruitment email was sent to all the employees by the facility manager of the company. This mail provided some general information about the trial and mentioned the incentive (€100) for participating in this trial. A total of 22 responses were received out of approximately 500 recruitment emails sent.

The 22 respondents received a second email with a short questionnaire. This questionnaire was used to gather information about the route the respondents normally take to and from work along with general and demographic information about the participant (e.g. age, gender, vehicle ownership, make of vehicle, frequency of other people using the vehicle). Based on the information gathered from the questionnaire, eight respondents were selected to participate in the trial. The participants were selected to have the pre-selected intersection on their route from home to work.

3.2.2 Procedure

Briefing and informed consent

The participants were briefed in two groups (of four participants each) on two different days. During the briefing, information was given about naturalistic driving observations in general and about this study in particular. Information was given about the installation of the observation equipment into their cars and about the potential risks and discomforts related to the participation and the privacy and liability policy. The specific goals and research questions of the trial were not revealed. The participants were explicitly given the opportunity to ask questions.

After the briefing, the participants were given the consent forms (see Appendix I). The participants were asked to read it carefully and return the signed consent form, if they agreed with the content, later that day after the observation equipment had been installed in their vehicles. This gave the participants the opportunity to thoroughly read the consent form. It was agreed with the participants that if, for any reason they could not agree with the consent form, the observation equipment would be de-installed on the same day.

The consent form contained general information about the trial, equipment installation procedure and described the privacy and liability policy for the trial. The consent form ended with nine statements that participants were asked to sign for (as follows, translated from Dutch):

- I confirm having read and understood the above provided information and agree to take part in the described research.
- I have a valid driver's license.
- My vehicle is insured (liability Insurance) and my insurance company stated that participating in this trial does not invalidate the insurance.
- I have been given the opportunity to think about the above provided information and, if necessary, ask questions to the experimenter and I have had enough time to decide to participate or not.
- I understand that employees of SWOV (Institute for road safety research) will have access to my data obtained in this study for a proper implementation of the above-mentioned study.
- I understand that my participation in this study is voluntary and that I have the right to stop participating at any time
- I have been given the opportunity to inspect the observation equipment that has been installed in my vehicle and confirm that the equipment will have no effect on driving the vehicle.
- I understand that I have to inform other drivers of this vehicle about this study. I will make sure other drivers of this vehicle will read and sign the form for 'other drivers' and send the form to SWOV.
- I accept the conditions and risks that are described in this form and will not hold SWOV or TNO liable for any damage as a result of an accident or burglary.

After de-installation of the equipment, the participants were given another form about the use of video material. In this form, the participants could give permission for other use of the video material apart from the analysis (see further in this section "de installation and debriefing").

Data acquisition system installation

The installation of the observation equipment was done by a professional garage in the vicinity of the company where the participants were recruited. Two employees of the garage drove the participants' vehicles from the company to the garage. First, a fused permanent connection with the vehicle's starter battery was made. Then, all the wires for the peripheral devices were hidden behind the carpet and plastic covers. The two cameras were mounted behind the rear-view mirror (Figure 41) and the GPS antenna was mounted on top of the dashboard under the windscreen. In most cases the main unit was installed under the driver's seat (Figure 42). In one occasion there was too little room under the driver's seat to place the main unit. In that case the main unit was

placed in the trunk of the vehicle. The main unit was secured on the carpet using Velcro.



Figure 41. Two camera's mounted with suction mounts behind the rear view mirror.



Figure 42. The Data Acquisition System installed under the driver's seat

After the main unit and the peripherals were installed, the mounting of the cameras was adjusted using a portable monitor. Finally, the internal accelerometer of the main unit was calibrated (set to zero for its current position). The average installation time of the equipment was three to four hours per vehicle. In total, four vehicles were equipped with the observation equipment on one day by two employees of the garage.

In some vehicles, the suction mounts of the cameras were visible from the outside. Because participants might feel uncomfortable with the observation equipment being visible from the outside, they were given the option to have a piece of tinted foil applied to the windscreen. The tinted foil, applied by a professional company, obscured the suction mounts without interfering with the normal drivers' sight (Figure 43). In total four participants opted for the tinted foil.

To ease the identification of the vehicles that participated in the in-vehicle trial in the site-based data, on all vehicles a magnetic white "dot" was applied to the roof of the vehicle (10 cm in diameter) (Figure 44).



Figure 43. Tinted foil applied to the windscreen to obscure the camera mounts.



Figure 44. Magnetic white "dot" applied to the roof

Data retrieval

Data retrieval from the main unit was done weekly on the premises of the participants' company. A few days before a "data retrieval day", an email was sent to all the participants to announce the date and time of the data retrieval and ask for their availability. To minimise the amount of effort needed from participants on a data retrieval day, the participants were asked to hand in the key of their vehicle at the reception of the company when they arrived at work. This enabled retrieval of the data from the vehicle without the need of the participant being present. When the data retrieval was done, the vehicle key was returned to the reception. All participants agreed on this procedure. On average, every participant was available for data retrieval every other week.

All the data were transferred from the main unit's Compact Flash card to a laptop using a card reader. From the laptop the data was transferred to the SWOV server. Only data that already had been transferred from the laptop to the SWOV servers (from a previous data retrieval) was deleted from the Compact Flash card. This ensured always having a backup available. During the data retrieval, the correct functioning of the DAS, the correct mounting of the cameras and the presence of the magnetic dot were also checked. On average the whole data retrieval and routine check procedure took half an hour per vehicle.

All data stored on the laptop was transferred to the SWOV servers in the SWOV premises using a wired network connection. Once the data was stored on the servers, it was deleted from the laptop. Only researchers involved in the research project had access

to the data. In total, an amount of 200 gigabyte data (580 recorded trips containing 1320 triggered events), were collected during the eight week observation period.

De-installation and debriefing

After the eight week observation period, the observation equipment was removed from the participants' vehicle by the same garage that installed the equipment. The vehicle was returned to the participant who was given the opportunity to inspect the vehicle and ensure no damage was done to it. If no damage was found, the participant signed a form stating that: a) they have had the opportunity to inspect the vehicle for damage as a result of installing and de-installing the observation equipment, and b) no damage was found as a result of installing and de-installing the observation equipment.

After that, the participants were given another form about the use of video material. In this form, the participants could give permission for other use of the video material apart from the analysis. Participants had the following options (translated and summarized from Dutch):

- I give permission to use video stills (single frames) in (scientific) publications
- I give permission to show video clips at conferences or other scientific meetings. SWOV will only show the video clips and not give any copies of these clips to other parties.
- SWOV may contact me to ask permission to use a specific video clip for other uses than described in this document (media attention for example).

In case the participants didn't want to give permission to use the video material for any other purpose, they could choose:

- I don't give permission to use the video material for any other purpose than the analysis necessary in this research project.

Finally, a short debriefing about the Dutch field trial in general was given and the participants were given the opportunity to ask questions about the study.

3.2.3 Data handling

In order to analyse the data with commonly used software tools, first all the data had to be converted from the propriety format to a more commonly used format, in this case the comma-separated-format (CSV). The software supplied with the pdrive system had the ability to convert the data to the CSV format for single data files. To automate the conversion process, scripts were developed to batch process all the data.

After the conversion, the relevant data episodes for the analysis had to be identified. The relevant episodes were the occasions where the participants crossed the specific intersection (Figure 45), approaching from the Western leg making a right turn on the intersection to the Southern leg. These episodes were identified by searching in the CSV trip files for the presence of two specific GPS coordinates, indicated as point A and B in Figure 45. If the two GPS coordinates were present in a single trip file in consecutive order, the participant had to have made the pre-selected right turn manoeuvre.

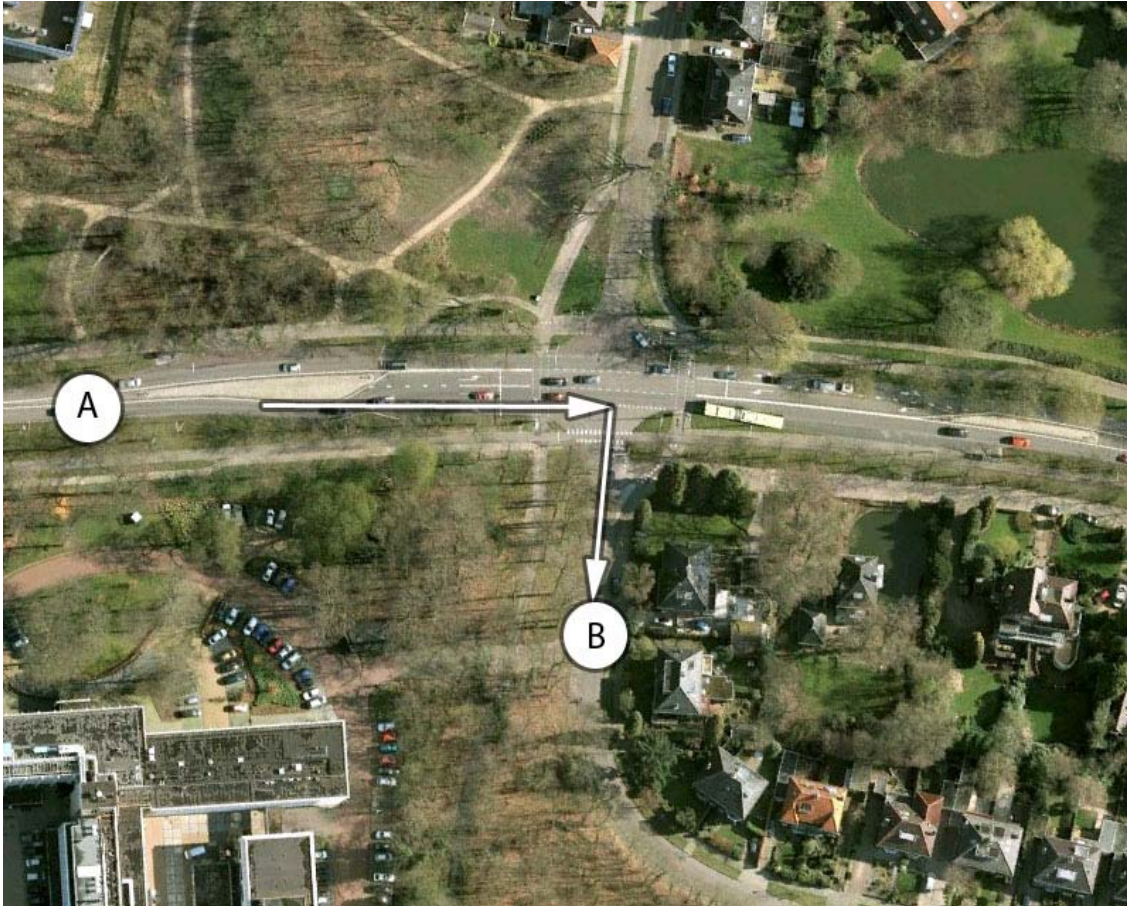

Figure 45. Illustration of intersection and the right turn manoeuvre

A total of 14 episodes were identified. This number was lower than expected. Two reasons were identified that seem to have affected the number of specified intersection crosses. First, although all participants crossed the specific intersection on their route from home to work, only one of them crosses the intersection in the defined direction, approaching from the west, on a regular basis. Second, for the first two weeks of the eight week observation period, the location-based video recording didn't function. A software update of the DAS resolved this issue. In addition, there are indications that the DAS didn't record every trip the participant had driven. One indication for missing trips, is the situation where for a specific participant, only the trip from work to home was recorded (afternoon), the trip from home to work (morning) is missing. A number of such irregularities were found. For 3 of these 14 episodes the glancing behaviour could not be coded because the participants wore sunglasses. From the remaining 11 episodes, 8 episodes were in the timeframe of the site-based observation. For the analyses of the in-vehicle data, the data of the 11 episodes where the participants made the right turn manoeuvre on the specified intersection were used.

For two cases, both in the non-halted situation, no speed and acceleration data could be determined due to corrupt data files. This data file corruption affected the ability to combine sensory measures (speed and accelerations) to the video data which is needed for example to determine the exact point (in time) where the vehicle entered the Conflict Area in the sensory data.

3.2.4 Data coding

Once the relevant data episodes were identified, the glance behaviour of the participants making the right turn manoeuvre was coded from the video data. First, the area for which the glance behaviour would be coded was defined. This area was defined as the *Area Of Interest (AOI)*, and is the area where the vehicle entered the right turn lane until the vehicle left the bicycle crossing. This is illustrated by the white surface in Figure 46). The *Conflict Area (CA)* is the area where a possible conflict between the right turning vehicle and a cyclist could occur. The Conflict Area is situated in the AOI. In Figure 46 the Conflict Area is hatched.



Figure 46. Illustration of the Area Of Interest (AOI) (highlighted area) and the Conflict Area (CA) (hatched area).

For each episode where the participant was in the Area Of Interest (AOI), the following variables were coded from the video data:

- *Time entering AOI*, Time on timeline of the trip when entering the Area of Interest. The event of entering the AOI was coded from the video data. The spatial resolution of the GPS signal was too low (error margin of 5 meters) to accurately capture the event of entering the AOI. The position of the vehicle in relation to reference points on the road (road markings) recorded in the video data were used to determine the time of entering the AOI (see Figure 47 for an illustration)

- *Time leaving AOI*, time on timeline of the trip when leaving the Area of Interest (see Figure 47 for an illustration of the reference point used)
- *Duration in AOI*, total time the vehicle was in the Area of Interest (in milliseconds) (derived from the time between entering and exiting the AOI)
- *Time entering CA*, time on timeline of the trip when entering the Conflict Area. Leaving the Conflict Area is the same as leaving the Area of Interest. (see Figure 47 for an illustration of the reference point used)
- *Vehicle state before manoeuvre*, the state of the vehicle, halted/non-halted, before beginning the right turn manoeuvre.
- *Time traffic light turned green*, time on timeline of the trip when the traffic light turned green
- *Time direct glance*, direct glance is the event where the participant would look directly at the area where cyclists could be expected. The start time on the timeline and duration (in milliseconds) of each glance, while in the Area of Interest, was coded.
- *Time indirect glance*, indirect glance is the event where the participant would look indirectly, through one of the vehicles mirrors, at the area where cyclists could be expected. The start time and duration (in milliseconds) of each glance, while in the Area of Interest, was coded.
- *Number of times direct glance*, The number of times for each episode in the Area of Interest a direct glance was observed
- *Number of times indirect glance*, The number of times for each episode in the Area of Interest an indirect glance was observed



Figure 47. Upper left: reference point for entering the Area of Interest. Upper right: reference point for leaving the Area of Interest. Lower left: reference point for entering the Conflict Area.

Glance direction, specifically the distinction between *direct* and *indirect glances* could easily be identified from the video data. Most distinctive feature between the *direct* and *indirect* glance was head and body movement. A *direct glance* was always accompanied by a head and/or body movement in the direction of the glance whereas the *indirect glances* most often only involved eye movements.

Participants glance behaviour was coded for the total duration that the vehicle was in the AOI (Figure 46). In the halted situation, where the participants had to wait for the traffic light to turn green, participants could be waiting in the AOI for minutes compared to only seconds in the non-halted situation. This waiting time could possibly effect the total duration and number of times the participants look for cyclists. In fact, this waiting time would introduce an extra independent variable, if the glance behaviour in the halted situation would be compared with the non-halted situation.

To make the glance behaviour data comparable between the halted and the non-halted condition, the analyses were performed at the glance behaviour during the six seconds before entering the Conflict Area (CA) until leaving the CA was selected (see Figure 48).

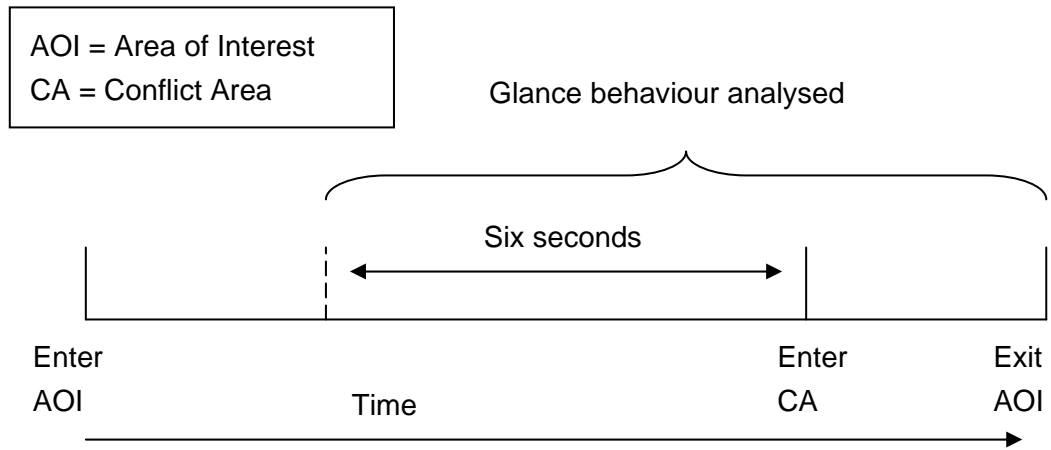

Figure 48. Illustration of glance behaviour analysed

4 Results

This chapter first presents the results of the site-based observation study (4.1), followed by the results of the in-vehicle study (4.2). In paragraph 4.3 the results of both studies and the overall research questions are presented.

4.1 Site-based observation

4.1.1 Counting road users (Manually & Automatically)

Total counts

The number of cars that turned right, which are non-halted (green traffic light) or halted (red light traffic light), versus cyclist that crossed the intersection for manual and automatic processing are shown in Table 9.

Table 9. Number of cars that turned right and the cyclists that crossed the intersection for manual and automatic processing on June 8th from 06:05 till 20:05

	Car right turn, non-halted		Car right turn, halted	
	Manual	Auto	Manual	Auto
No encounter with cyclist	210	167	68	112
Encounter with cyclist	29	43	78	82
Total	239	210	146	194

The results in Table 9 showed that the total number of counts for June 8th from 06:05 till 20:05 was almost similar for the manual (385) and automatic (404) processing (an error of 4.7 %). To consider the similarity between manual and automatic processing for smaller time steps, the counts per 15 minutes were compared.

Counts per 15 minutes

The results of counting the cars that turned right and the number of cyclists that crossed the intersection, crossing the path of the right turning cars, are shown in Figure 49 and Figure 50. Figure 49 shows the total number of cars that turned right for the manual processing and the automatic processing for June 8th 2010 from 06:05 till 20:05. These results also included cars that were almost entirely behind other vehicles, such as trucks and buses and were therefore hardly visible. These cars could not be tracked by the automatic processing, because in the video detection only the vehicles in front (e.g. trucks and buses) could be detected. Furthermore, for the traffic analysis of the encounters between the right turning cars and the cyclists, it was necessary to determine the paths of the cars. In the manual processing these paths could only be determined properly if the wheels were visible and could be tracked. Therefore, the “invisible” cars that turned right were excluded from the counted cars. This resulted in a total of 385 right turning cars for the manual processing instead of 414. The results are shown in Figure 50.

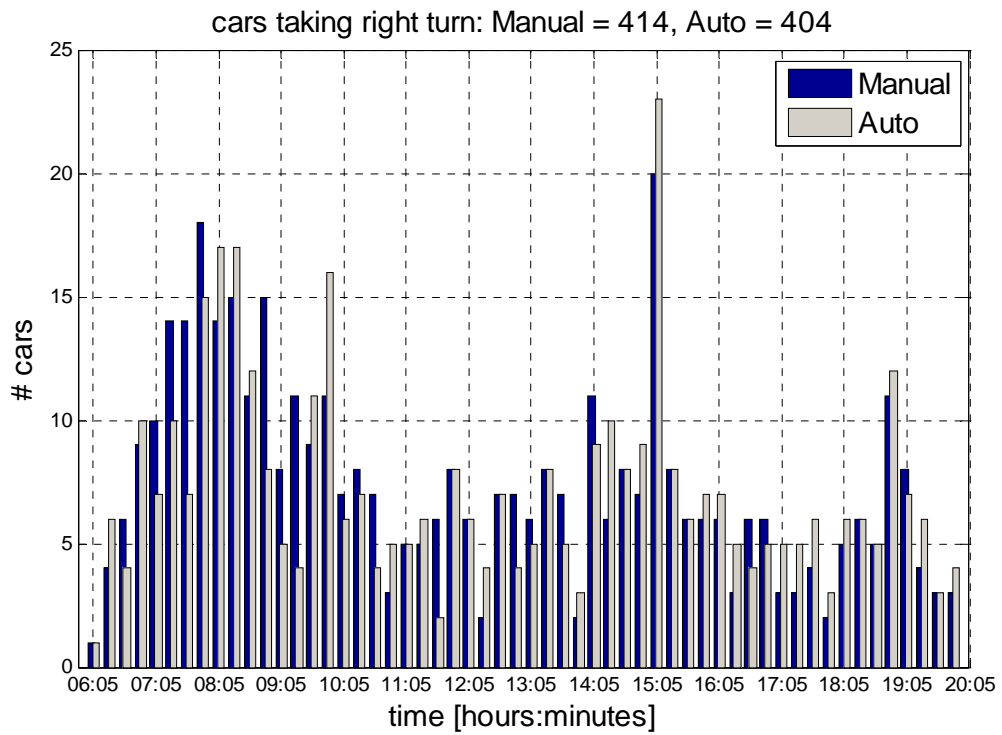

Figure 49. Total number of cars that turned right for Manual and Automatic processing

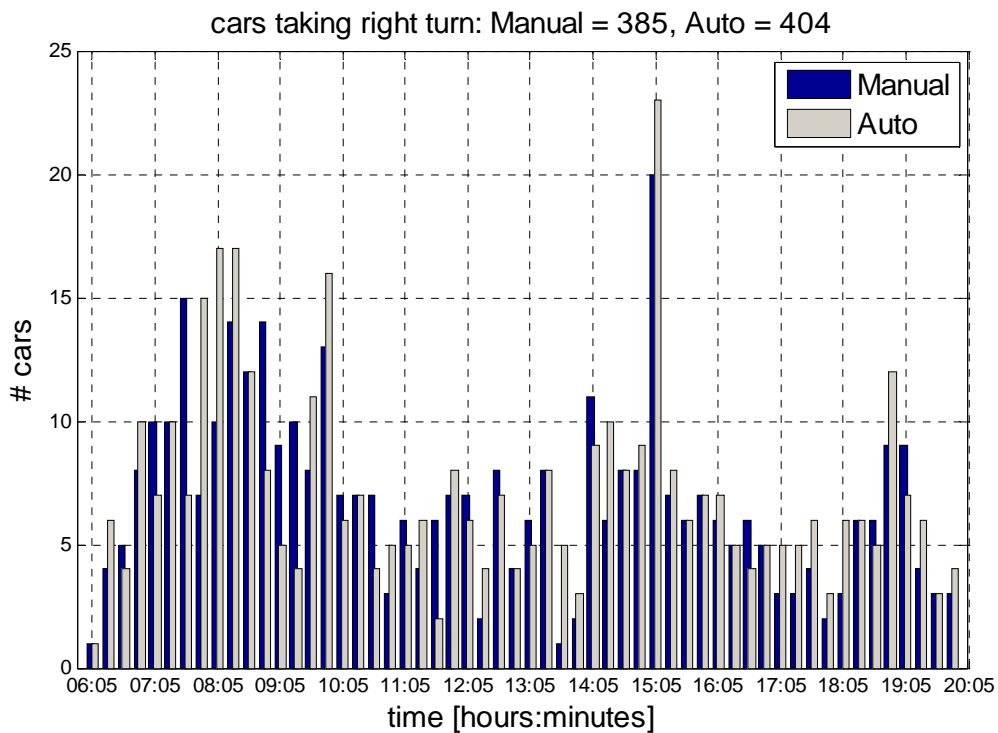

Figure 50. Total number of cars that turned right for Manual and Automatic processing

From the results in Figure 49 and Figure 50 it is shown that the patterns of the manual and automatic counting were similar, but there were quite a few small errors. The results of the number of errors are shown in Table 10, in which the difference of 0 means a similar result for manual and automatic counting, so no error. The difference of 1 means that the number counted manually was 1 smaller or higher than the number that

was counted automatically. The same goes for the other numbers. Here it is shown that 84% (= $100\% * (13+14+12+8)/56$) of the errors were equal or smaller than 3.

Table 10. Differences between manual and automatic counting

Differences between manual and automatic processing (for Figure 50)	
Error	# of 15 minutes periods
0 (similar result)	13
1	14
2	12
3	8
4	4
5	0
>5	5
Total # of time periods of 15 minutes	56

The small errors were generally caused by the fact that the vehicles that turned right at the intersection included cars and *trucks* in the automatic processing. To determine the different types of road users extra filtering was needed as was explained in Step 1 in subsection 3.1.2. On June 8th there were 11 trucks that turned right. In the manual processing only cars were considered.

A second cause of the small errors was that in the manual processing the cars that were hardly visible, because they were almost entirely behind other vehicles, were not taken into account as was explained previously. These were in total 29 “invisible” cars. Some of these cars were detected in the automatic processing.

A third cause of the small errors was the way that right turning cars were selected in the automatic processing to be considered as a right turning car. To check the vehicles that turned right, a certain region (from the top view) was determined as was explained in step 4, subsection 3.1.2. If vehicles crossed this region, it was assumed that this vehicle turned right at the crossing. The accuracy of the automatic counting was thus largely dependent on the determination of this region. If the detection of a vehicle was not that accurate, the path of this vehicle could have been outside the detection region and thus was not counted as a vehicle turning right, although the vehicle actually turned right in reality.

Considering the counts of 7:35 t through to 7:50, there were 15 cars that turned right according to the manually counting and 7 according to the automatic counting. The error between the real number of cars that turned right and the number that was counted automatically was 8. When the results of the automatic counting were considered in more detail, it seemed that these missing 8 cars were detected, but the paths of these cars did not cross the detection region, to allow selection of the cars that turned right in reality. If the paths do not cross the region to select the paths of the cars that turn right, they will not be counted as right turning cars.

Optimizing the selection region could improve the counting results of the automatic processing. However, there will always be some error, because optimizing the region is always a compromise. There will always be some errors, for example because the cy-

clists did not follow the traffic rules and did not ride on the cycle path. These should then be filtered out.

Non-halted and halted right turning cars for manual and automatic processing

Figure 51 and Figure 52 show the number of cars that turned right and had a green traffic light (non-halted) and red traffic light (halted) respectively at the intersection for the manual and automatic processing.

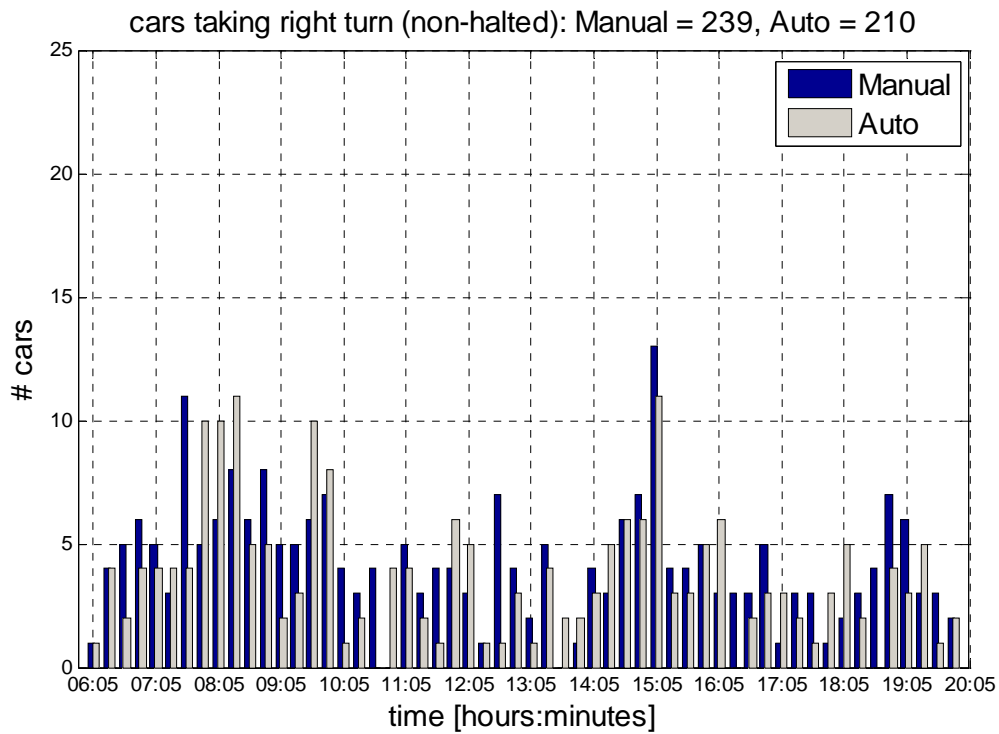

Figure 51. Number of cars turning right that had green light for manual and automatic processing

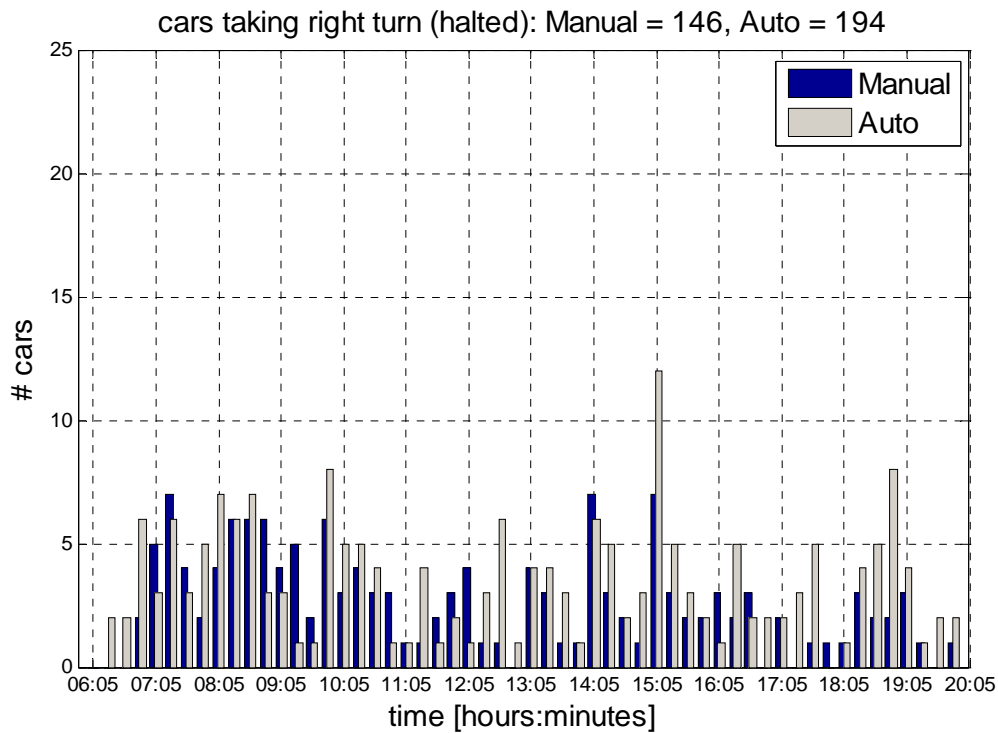

Figure 52. Number of cars turning right that had red light for manual and automatic processing

The differences between the manual and automatic processing are shown in Table 11. For the cars (no trucks) that had green light (non-halted) and red light (halted), respectively 86% (=100% * (6+18+13+11)/56) and 89% (=100% * (10+18+14+8)/56) of the errors were equal or smaller than 3.

Table 11. Differences between manual and automatic counting for non-halted and halted vehicles

Differences between manual and automatic processing (for Figure 51 and 52)		
	Non-Halted (green traffic light)	Halted (red traffic light)
Error	# of 15 minutes periods	# of 15 minutes periods
0 (similar result)	6	10
1	18	18
2	13	14
3	11	8
4	5	3
5	1	2
>5	2	1
Total # of time periods of 15 minutes	56	56

Three of the causes of these errors were already explained in the previous paragraph. A fourth cause could be due to the way that the non-halted and halted vehicles were detected in the automatic processing. This was already explained in step 5 in subsection 3.1.2. This was done by considering the speed of the vehicle in and just after the sorting box. If the speed was smaller than 20 km/h the vehicle was counted as halted.

This was also verified by the speeds that were measured by the instrumented vehicle of the SWOV. It could however be that there were some vehicles that did not have to stop for the red traffic light, but had a speed that was below the 20 km/h in or just after the sorting box. This should be analyzed in more detail.

Total number of cyclists for manual and automatic processing

The number of cyclists that crossed the path of right turning cars is shown in Figure 53.

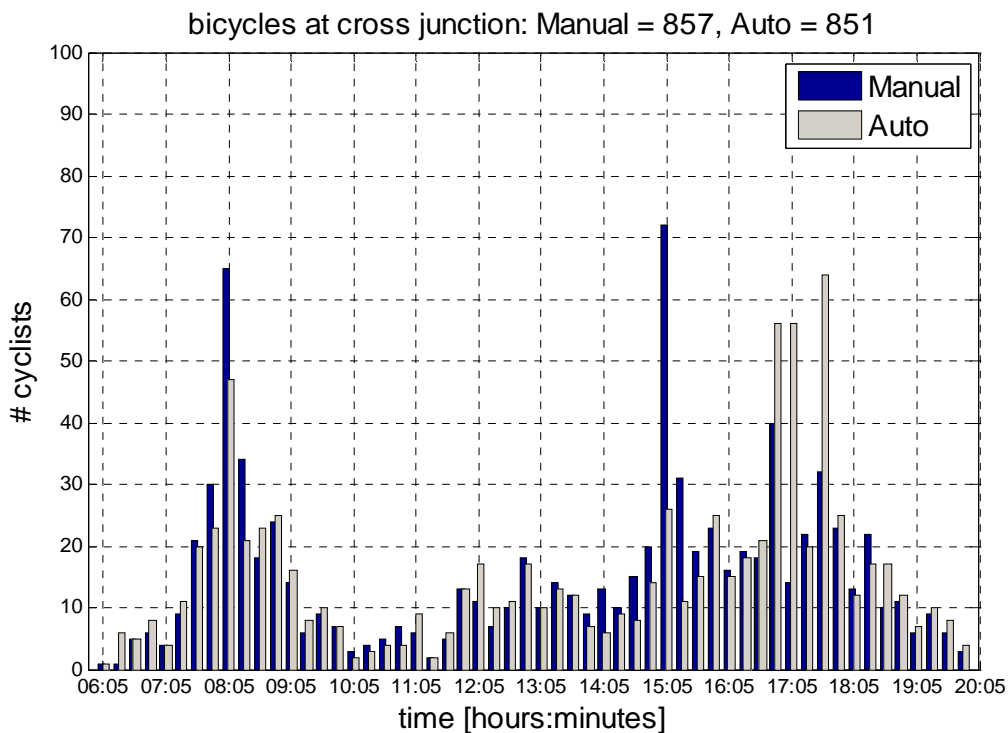

Figure 53. Total number of cyclists that crossed the path of the right turning cars for Manual and Automatic processing

The results of the errors between the manual and automatic counts are shown in Table 12. Of these errors, 70% (=100% * (8+18+9+4)/56) were equal or smaller than 3 counts.

The errors were generally caused by the fact that in the automatic processing mopeds were also counted as cyclists, while in the manual processing these were excluded.

There were also a few larger errors, for example at 8:05 and 15:05. It is shown that there were far more manual counts than automatic ones, 65 versus 47. When the video data was studied in more detail, it was noticed that at these times there were a lot of groups of cyclists, students that went to and from school. The automatic processing could not always distinguish all the cyclists within the group and sometimes counted two or more cyclists as one cyclist. This resulted in less cyclists than were counted manually.

Considering the mismatch between manual and automatic counting at 16:50 till 17:05, 17:05 till 17:20 and 17:35 till 17:50 it is shown that there were more cyclists counted automatically than manually. This was caused by rain drops. It was raining heavily and the video detection counted some of the rain drops as cyclists. Therefore the number of cyclists was larger than the number of cyclists that were counted manually.

Table 12. Differences between manual and automatic counting of the cyclists

Differences between manual and automatic processing (for Figure 53)	
Error	# of 15 minutes periods
0 (similar result)	8
1	18
2	9
3	4
4	1
5	3
>5	13
Total # of time periods of 15 minutes	56

Encounters

The results for counting the encounters between the cyclists and the non-halted and halted cars that turned right are shown in Figure 54 and Figure 55.

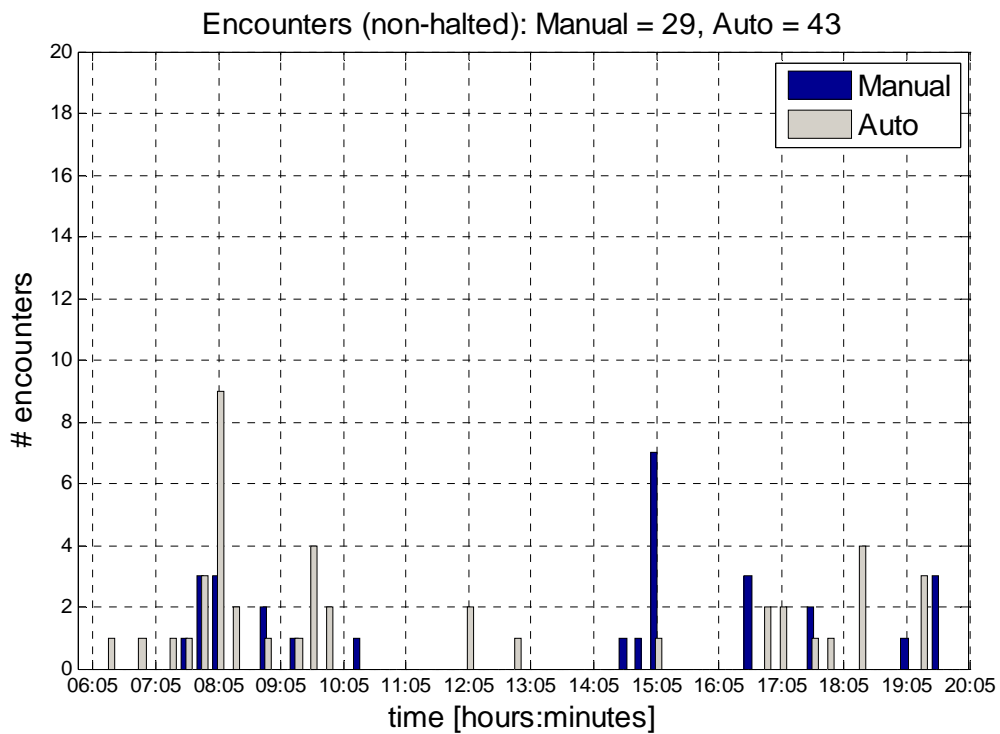

Figure 54. Number of encounters between non-halted cars and cyclists for manual and automatic processing

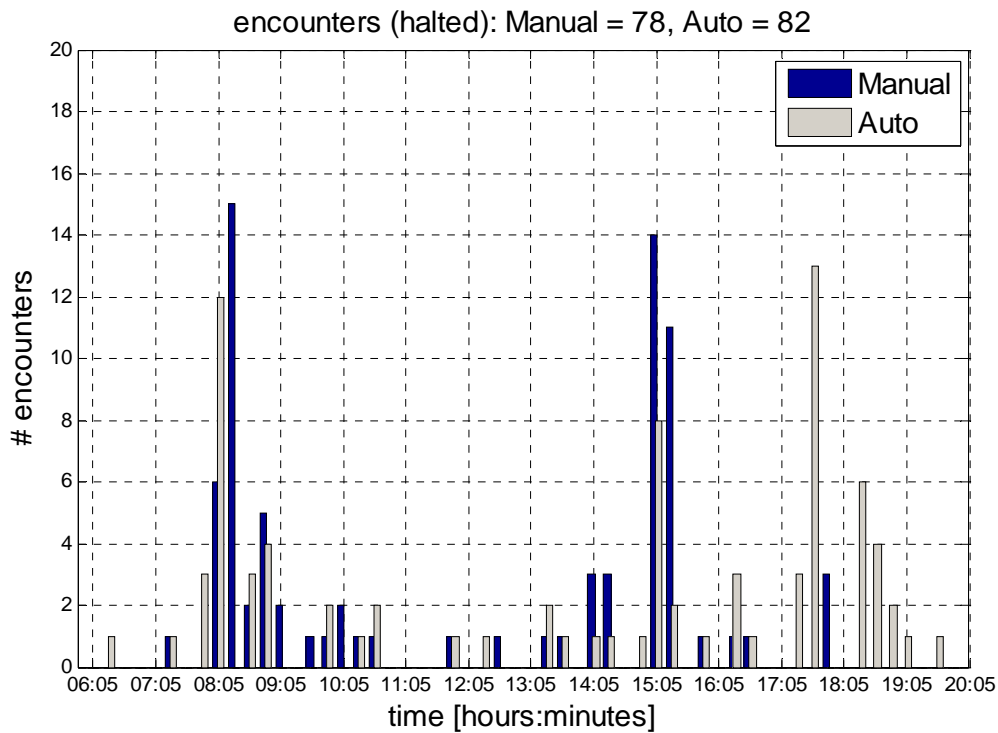

Figure 55. Number of encounters between halted cars and cyclists for manual and automatic processing

The differences between the manual and automatic processing are shown in Table 11. For the encounters of which the cars had green light (non-halted) and red light (halted), respectively 93% (=100% * (33+11+5+3)/56) and 88% (=100% * (28+12+6+3)/56) of the errors were equal or smaller than 3 counts.

Table 13. Differences between manual and automatic counting for the encounters for non-halted and halted vehicles

Differences between manual and automatic processing (for Figure 54 and 55)		
	Non-Halted (green traffic light)	Halted (red traffic light)
Error	# of 15 minutes periods	# of 15 minutes periods
0 (similar result)	33	28
1	11	12
2	5	6
3	3	3
4	2	1
5	0	0
>5	2	6
Total # of time periods of 15 minutes	56	56

When the large errors (>4) between the manual and automatic counting of the encounters were analyzed in more detail, it was noticed that most large errors were caused by the wrong detection of the cyclists that was explained in the previous paragraph. The large errors occurred for the non-halted vehicles at 8:05 till 8:20 and 15:05 till 15:20. These were just the time periods in which there were large groups of cyclists of which a couple of cyclists were counted as one in the automatic processing. The large errors for the halted vehicles occurred also at 8:05 till 8:20 and 15:05 till 15:20, but also at 8:20 till 8:35, 15:20 till 15:35, 17:35 till 17:50 and 18:20 till 18:35. The errors at 8:20 till 8:35, 15:20 till 15:35 and 17:35 till 17:50 were caused by the large errors in the cyclist count. The error in 18:20 till 18:35 was mainly caused by an error in the manual counting. There were in reality 4 encounters, while the result of the manual counting showed a result of 0 encounters.

4.1.2 Speed estimations

The speed of the vehicles was calculated by the manual and automatic processing. The differences between the speed estimated by the manual and automatic processing was analyzed by considering, as an example, the speed profile of the vehicle that was equipped with in-vehicle data logging that turned right on the intersection at June 8th at 07:55 in the morning. The results for the manual and automatic processing are shown in Figure 56.

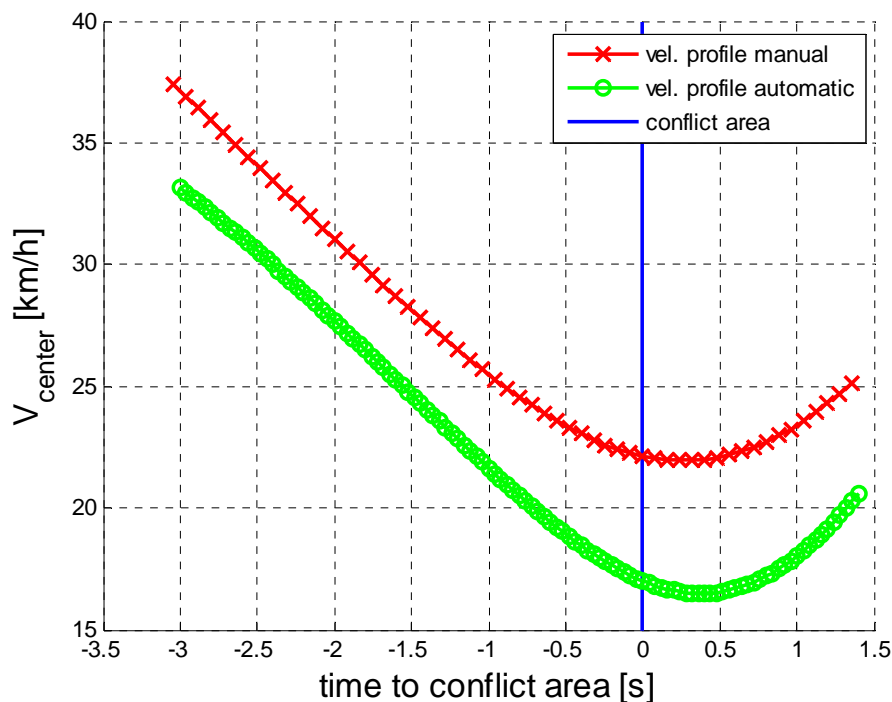

Figure 56. Difference in speed estimation for manual and automatic processing for the instrumented vehicle that turned right on the intersection at June 8th at 07:55

In Figure 56 it is shown that the speed estimated by the automatic processing is less than the speed estimated by the manual processing. At 3 seconds before entering the conflict area, the speed estimated by the automatic processing is 4km/h lower than for the manual processing. When entering the conflict area, this difference is increased to 5.5 km/h. This can be explained by the error in the path estimation when processing the video data automatically as was explained in subsection 3.1.2. A better estimation of the travelled path will also improve the estimation of the speed profile. The results are representative for the other cases too.

One of the inputs in the 2x2 research design matrix (see Table 1) is the speed profiles of the cars taking a right turn for the (non-)halted situations. Therefore the velocity of the cars is determined when they enter the conflict area. The conflict area is shown as the red rectangle in Figure 57. Second the derived speed profile of the car is shifted, to set the time equal to zero when it enters the conflict area, as discussed in step 8 of paragraph 3.1.1. and shown in Figure 58.

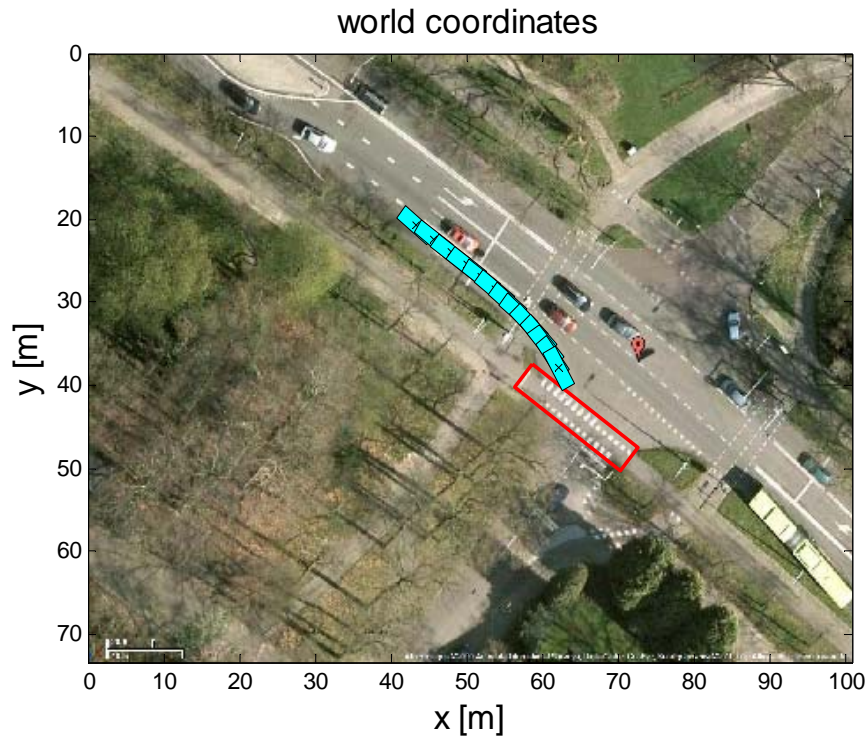

Figure 57. Car enters the conflict area (red rectangle)

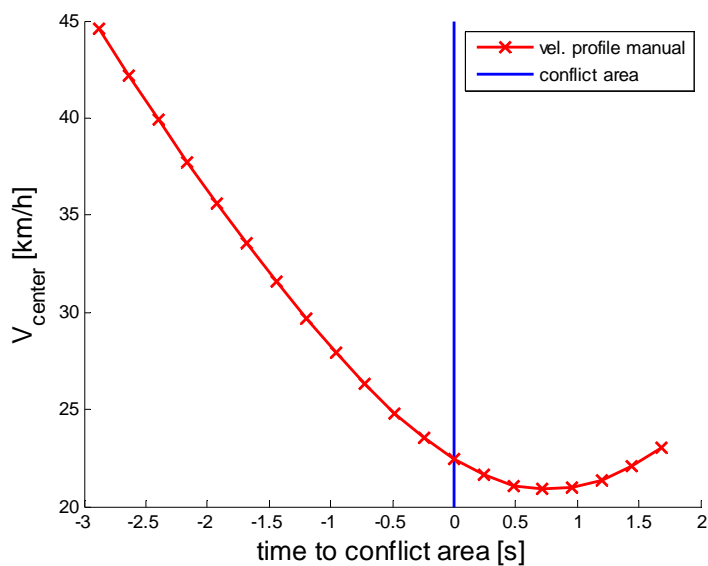

Figure 58. Velocity profile with regard to the conflict area

To compare the velocity of cars between the different situations the average (mean) and standard deviation (sd) of the velocity when it enters the conflict area are calculated. Also, the minimal velocity of the whole speed profile is compared. This results into the following input for the 2x2 research design matrix, as shown in Table 14.

Table 14. Mean and sd of cars entering the conflict area and the minimal velocity of the whole speed profile

		Halted situation			Non-Halted situation		
		Nr. of cars	mean [km/h]	sd [km/h]	Nr. of cars	mean [km/h]	sd [km/h]
Cyclist	at conflict area	38	16,76	5,1	15	14,73	8,2
	minimal velocity		7,82	3,8		13,79	8,2
No Cyclist	at conflict area	110	19,53	4,223	224	21,83	4,5792
	minimal velocity		10,58	4,579		20,70	5,3352

It can be seen that when a car enters the conflict area the mean velocity is larger when there's no cyclist present (16.6 [%] in halted situations and 42.5 [%] in non-halted situations). The mean of the minimal velocity of the whole speed profile is 67 [%] larger for non-halted situations compared with the halted-situations when there's a cyclist present and 95 [%] when there's no cyclist present.

4.1.3 Traffic safety measure: Time-To-Collision (TTC)

To determine the TTC of a potential conflict between a car and cyclist, synchronization has to be performed to set the position of the car and cyclist at exactly the same time (as discussed in chapter 3). Unfortunately, a TTC could not be determined of the potential conflicts of the manual tracked data due to the following:

1. Synchronization at the exact same time of the car and cyclist could not be performed by the fact that car and cyclist have been manually tracked separately.
2. After synchronizing of the car and cyclist of a potential conflict, not enough data of the tracked path was left to determine a TTC using extrapolation.
3. On halted situations; the cyclist was halfway across the intersection at the time the car received a green light to start taking a right turn. These situations were marked as potential conflict, although a possible conflict for a TTC could not occur.

In order to have at least an idea of the number of conflicts between right turning vehicles and bicyclists on the encounters that were included in the period covered (June 8, 2010, 6:05 till 20:05), all encounters that were manually detected from video (see Table 9) were subject to an inspection from video by an experienced DOCTOR traffic conflict observer to make a judgment of the encounter according to the DOCTOR methodology (Kraay, van der Horst & Oppe, 1986). This procedure has been successfully applied in several other behavioural studies (for example Van der Horst et al., 2007).

In the Netherlands, the DOCTOR (Dutch Objective Conflict Technique for Operation and Research) method was developed by the Institute for Road Safety Research (SWOV) and TNO Human Factors. This TCT was primarily a result of an international calibration study which took place in Malmö under the auspices of the ICTCT (International Cooperation on Theories and Concepts in Traffic Safety) in order to compare existing techniques (Grayson, 1984). A comparison with video-taped conflicts and accidents (Van der Horst, 1984), indicated that severity scores, performed by individual observers, were mainly correlated to TTC and type of accident. The DOCTOR technique identifies a critical situation if the available space for manoeuvre is less than is needed for normal reaction (Van der Horst, & Kraay, 1986). The severity of the conflict is then scored on a scale from 1 to 5, taking into account (1) the probability of a collision and (2) the extent of the consequences if a collision had occurred. The probability of a collision is determined by the Time-To-Collision (TTC) and/or the Post Encroachment Time (PET) (Van der Horst, 1990). The extent of the consequences if a collision course had occurred is mainly dependent on the potential collision energy and the vulnerability of the road-users involved. Affecting factors are the relative speed, available and necessary space for manoeuvre, the angle of approach, the type and condition of road-users, etc. The mass and manoeuvrability of the vehicles are very much determining the final outcome. To obtain an as unambiguous estimate as possible of the injury severity and for additional information for analysis and diagnosis, several aspects are scored and registered on the observation sheet. For this methodology a manual has been developed in which DOCTOR is described in detail (Kraay, Van der Horst & Oppe, 1986).

The figures in Table 9 represent all bicyclists passing, whereas in this inspection only the most critical bicyclist of a group of bicyclists was considered. This resulted in 15 non-halted Car right turn – Bicyclist situations and 38 halted Car right turn – bicyclist situations. The majority of these situations were dealt with rather smoothly with cautious and timely interaction between both. Of the 38 halted right turning car – bicyclist encounters, only 1 moderate conflict (DOCTOR score 2/3) was detected with an estimated minimum TTC of 1.1 s and a severity score of 2. Of the 15 non-halted car – bicyclists interaction, 4 encounters were scored as slight conflicts (DOCTOR score 1-2 (min TTC between 1.0-1,5 s or PET between 0.5 – 1.0 s, severity 1) and 1 as a moderate conflict (min TTC between 1.0 – 1.5 s, severity of 2). So, in general, it can be concluded that the non-halted right-turning cars are more involved in conflicts with bicyclists than the cars that start from a halted position. This can be explained by a specific feature in the signalization scheme with a pre-start for bicyclists at the beginning of the green phase.

4.1.4 Traffic safety measure: Post Encroachment Time (PET)

The PET was both calculated from the tracking data as described in Step 10 of the Manual Processing, referred to as *Matlab* (See paragraph 3.1.1) and from a manual inspection of the relevant video scenes by the DOCTOR expert, referred to as *Manual*.

Due to an error in the Matlab script, Matlab could only compute a PET value for a subset of the encounters. The script was only completed for the situation that the bicyclist would pass in front of the right turning vehicle. In total, for 4 encounters the opposite situation was true (vehicle passed in front of bicyclist) and no calculation could be conducted yet. The total number of encounters from both approaches is presented in Table 15.

Table 15. Total number of encounters by DOCTOR PET-categories as derived from the Matlab calculations and from manual inspection of the video images by a DOCTOR expert.

PET (s)	Halted		Non-halted		Total	
	Matlab	Manual	Matlab	Manual	Matlab	Manual
0.0-0.5	0	0	1	1	1	1
0.5-1.0	1	3	2	2	3	5
1.0-1.5	4	4	1	5	5	9
1.5-2.0	4	4	0	4	4	8
>2.0	21	27	2	3	23	30
Total	30	38	6	15	36	53
Average PET (s)	2.88	3.00	1.75	1.60	2.69	2.60

Although the total number of non-halted encounters is rather limited, the general picture is that the average value of PETs for the non-halted encounters is much lower than for the halted encounters. As explained in the TTC section, this may well be because of the specific arrangement in the signalization scheme at this intersection. Figure 59 gives the comparison between the two approaches when corrected for the total number of encounters. The overall picture is that both approaches give similar results relative to the DOCTOR PET categories.

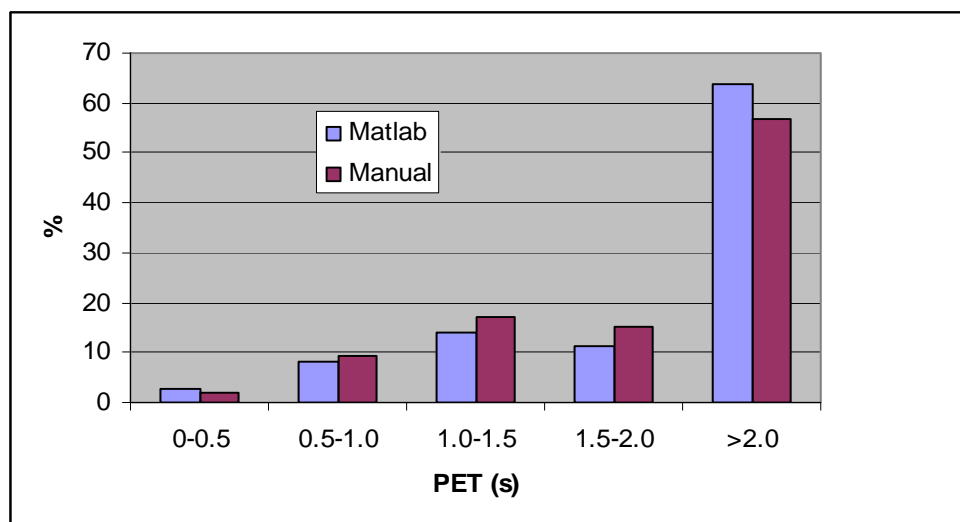

Figure 59. Comparison of the Matlab calculations of PET values ('Matlab', n = 30) and the manually derived PET values from video by DOCTOR expert ('Manual', n = 53)

4.1.5 Conclusions - site-based observation

Overall the errors of the automatic counting were small compared to the manual counting. The error of the total number of right turning cars counted for one day (06:05 to 20:05) was less than 5%. When the automatic counting was compared to the manual counting for every time period of 15 minutes the error for counting the number of cy-

clists was largest; 8 of the 56 time periods of 15 minutes were counted correctly. This result does not look promising. However, the errors that were made by the automatic counting were small. 70% of the errors for counting the cyclists were smaller than 3 counts. For counting the right turn cars and the encounters this was 84% or higher.

From these results we conclude that the automatic counting with one camera viewpoint is not always very accurate in counting cyclists, especially if individual cyclists have to be detected in a group of cyclists.

The automatic counting of cars gave some minor errors. These minor errors could be decreased by improving the filters that were used for the road user detection and by having more than one camera with more than one different view-point.

These different view-points were also needed to have a better estimation of the speed and to determine Time-To-Collision (TTC) and Post Encroachment Time (PET) automatically. These two traffic safety measures, TTC and PET, were considered in the manual processing analysis. It was impossible to determine TTC because of synchronization issues. In general, only a few encounters have been identified as a traffic conflict in terms of minimum TTC or PET. It clearly appeared that the non-halted encounters were relatively more critical than the halted encounters. This can be explained by a specific feature in the signalization scheme with a pre-start for bicyclists at the beginning of the green phase. The two approaches for deriving the PET values (Matlab calculations and manually from video by the DOCTOR expert) showed similar results. The Matlab approach, however, needs some further development to enable different types of encounters as has been identified in earlier research (van der Horst, 1990).

Although the automatic processing gave some (minor) errors for counting the road users compared to the manual processing, it also has an advantage over manual processing. The processing time, after having prepared the automatic algorithms, takes much less time than manual processing. This provides the opportunity to analyse a lot of different intersections for much more than the one-day example that we used in this study. When sticking to the absolute accurate manual processing, it becomes almost impossible (in terms of analysis time) to analyse a lot of intersections for more than a month.

Therefore it is concluded that it is worth investing in automatic processing. Prerequisites are that the number of camera view-points is increased for increasing accuracy in counting and to improve the filter algorithms. Accuracy in detection in following of a road user is already increased by added one or two extra camera's that view the intersection from the opposite site as the first camera. In this way a road user can be tracked by putting a stationary point on it. Turning movements can be followed more smoothly and disappearing behind another road user or object can be avoided.

4.2 In-vehicle observation

This paragraph presents the results of the in-vehicle trial. In the next paragraph, the results of the in-vehicle observation will be discussed in relation to the site-based observations.

4.2.1 Glance behaviour

The glance behaviour for the halted and the non-halted situation is presented in Table 16. The glance behaviour involves the durations and frequency of direct and indirect glances, the defined time frame (see paragraph 3.2.4). The average glance duration for the halted situation is longer for both the direct and indirect glance. Also the average

number of glances, both direct and indirect, is higher for the halted than the non-halted situation. There are also more direct than indirect glances. Because of the small number of observations, it was not possible to statistically test the significance of the differences found.

Table 16. Overview of glance behaviour in the halted and non-halted situation (1 standard deviation could not be calculated, mean based on single data point)

	Halted (n=3)	Non-halted (n=8)
Direct glance total (milliseconds)	M=1626 SD=244	M=1120 SD=356
<i>Ratio</i>	1,45:1,00	
Indirect glance total (milliseconds)	M=733 SD=129	M=600 SD= - ¹
<i>Ratio</i>	6,38:1,00	
Direct glance (number of times)	M=2.33 SD=0.6	M=1.75 SD=0.7
<i>Ratio</i>	1,22:1,00	
Indirect glance (number of times)	M=1.33 SD=0.6	M=0.13 SD= - ¹
<i>Ratio</i>	10,67:1,00	

4.2.2 Speed behaviour

Table 17 presents an overview of the results on speed, longitudinal accelerations and lateral accelerations. The presented figures are of the mean and standard deviations at the moment the vehicle enters the Conflict Area. The mean speed is lower in the halted situation. Also the mean lateral and longitudinal acceleration are lower for the halted situation than for the non-halted situation. Because of the small number of observations, it was not possible to statistically test the significance of the differences found.

Table 17. Mean and standard deviation of speed, longitudinal accelerations and lateral accelerations when entering the Conflict Area for the Halted and Non-halted situation

	Halted (n=3)	Non-halted (n=6)
Speed (km/h)	M=20.57 SD=1.59	M=23.02 SD=2.87
Longitudinal acceleration (m/s ²)	M=-0.07 SD=0.41	M=-0.49 SD=0.21
Lateral acceleration (m/s ²)	M=2.55 SD=0.24	M=3.24 SD=0.40

4.2.3 Glance behaviour in relation to the speed profile

To get a more in depth understanding of speed and glance behaviour during the right turn manoeuvre, these are related to each other in one graph (Figure 60). This graph shows one event where a participant makes the selected right turn from the halted situation. The moment the vehicle enters the Conflict Area with the front of the car is indicated in the graph by a vertical line. The participant is waiting at the red light. At $t=-4$ the vehicle's speed increases. At the moment of entering the Conflict Area (CA), the speed is just over 25km/h. This clearly shows a high longitudinal acceleration when the speed increases. The lateral acceleration increases from about $t=-2$ due to the turn that is being started.

The participant looks three times for cyclists. The first glance is indirect, at about $t=-4$ when the vehicle starts off. Then the participant looks twice directly to the right, once just before starting to turn (the lateral acceleration is about to increase) and once just before entering the Conflict Area (CA).

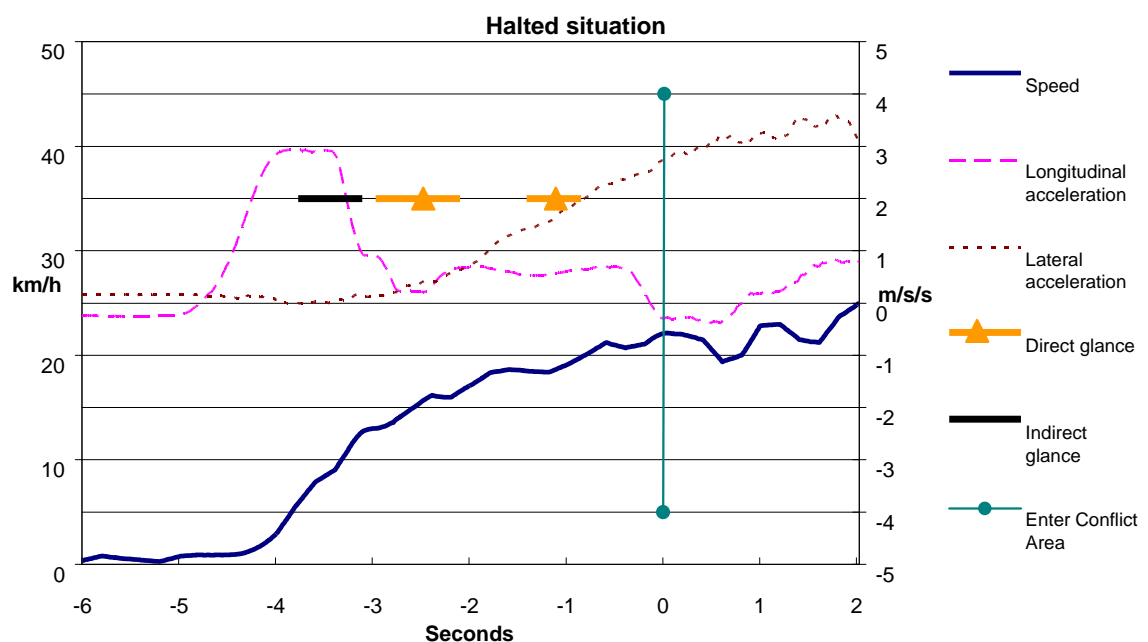

Figure 60. Glance behaviour in relation to speed behaviour

Figure 61 presents such graphs for each single episode. Looking at these graphs, the speed curves of the halted and non-halted situation clearly show different shapes. In the non-halted situation, the vehicles decelerate to the desired speed for making the right turn manoeuvre (descending speed curve) and in the halted situation the vehicles accelerate to the desired speed (ascending curve). In the halted situation, the participants seem to accelerate to the desired speed in a short period of time and then make the manoeuvre with a rather constant (or slowly ascending) speed. This behaviour is also indicated by the hyperbolic shape of the longitudinal acceleration curves in the halted situation.

The shape of the speed curves shows some inaccuracy (noise) of the GPS signal. In one graph for example, the speed ascends around 15 km/h in only a fraction of time.

The difference between the halted and non-halted situation can also be seen in the related longitudinal acceleration curves. The lateral acceleration curves show the onset

of the right turn manoeuvre. The onset of the right turn manoeuvre reflected by the lateral acceleration curves, resemble an exponential trend.

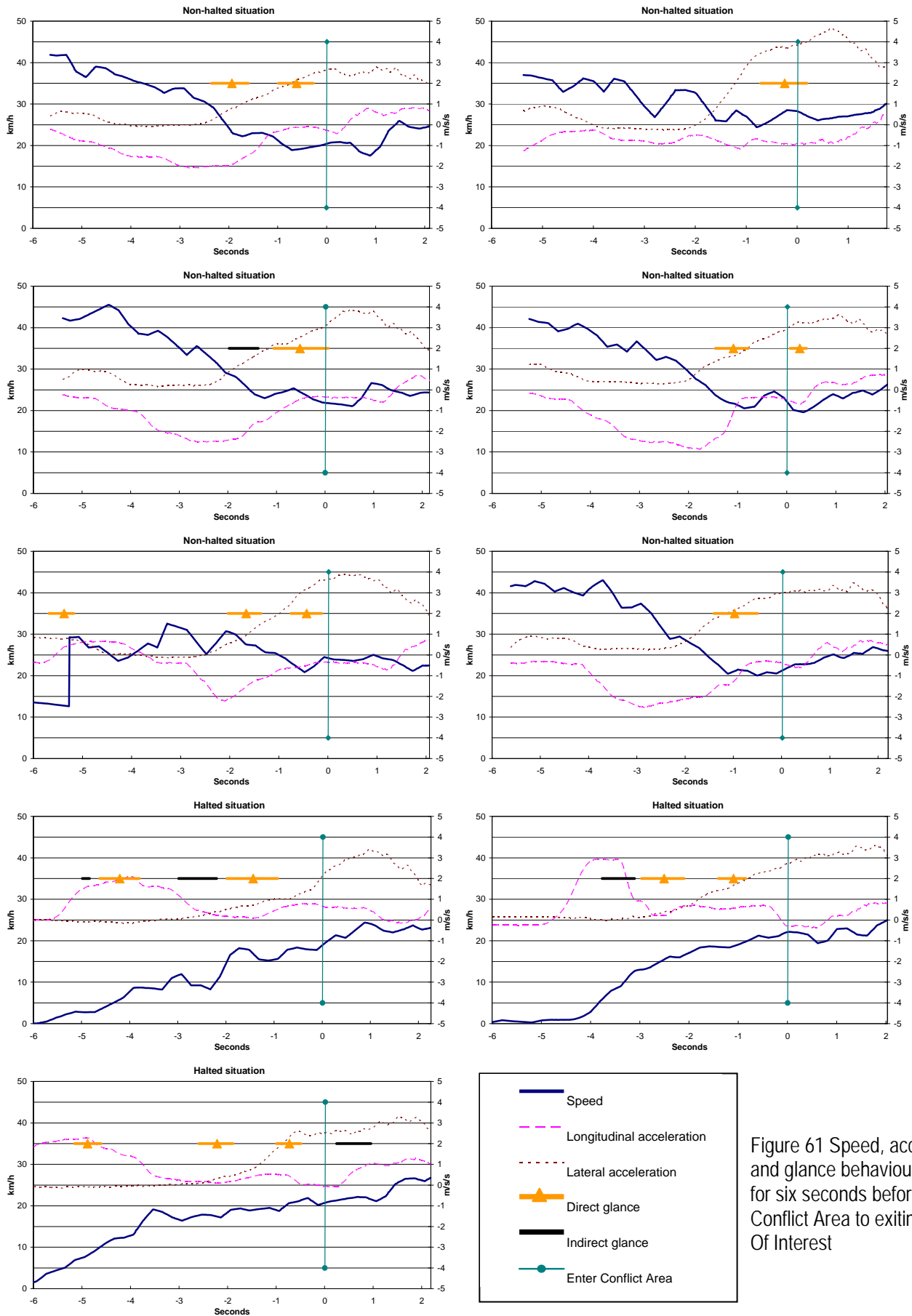

Figure 61 Speed, acceleration and glance behaviour Graphs for six seconds before entering Conflict Area to exiting the Area Of Interest

Regarding the glance behaviour in relation to the speed behaviour, the graphs show that in most cases the glance behaviour is performed before entering the Conflict Area. In most cases the participants has looked directly for cyclists once or twice between the onset of the right turn manoeuvre and entering the Conflict Area.

Finally, the halted situations show more indirect glances and in at least in 3 cases the indirect glance is immediately followed by a direct glance.

4.2.4 Conclusions in vehicle observation

Because of the small number of observations, we did not find any statistically significant effects supporting or falsifying the hypothesis postulated in paragraph 1.5.2.. However, the results indicate a non-significant trend supporting our hypotheses.

Both direct and indirect glance behaviour increased in terms of duration and frequency in the halted situation compared to the non-halted situation. This supports the idea that drivers might adapt their driving behaviour and take safety measures because they have a less accurate mental image of the presence of cyclists. Additional support for this idea comes from the speed and lateral acceleration measures. Both speed and lateral accelerations are lower in the halted situation compared to the non-halted situation. Crossing the Conflict Area with a lower speed allows the drivers more time to look for cyclist that might be on a conflicting path.

Also the study has provided insight in the looking pattern of the drivers. The results indicated that often drivers looked directly for cyclist once or twice between the onset of the right turn manoeuvre and entering the Conflict Area.

4.3 Combining the two observation methods

During the two weeks of site-based camera observation, 5 cars equipped with in-vehicle DAS took a right turn at the specified intersection. These were all non-halted situations. For these 5 cars the results of the site-based and in-car measurement of speed were compared. For the site-based measurement only the speed profiles that were derived manually were taken into account, because the speed that was estimated automatically contained an error as was shown in 4.1.2.

The combined velocity profiles are shown in Figure 62 to Figure 66. It shows that the velocities of the site-based and in-vehicle have a similar profile. However, differences between the profiles are visible. This difference can be explained on the one hand by a small error that is introduced when, during manual tracking of the site-based observation, not the exact wheel centre is selected. After transformation into world coordinates this can introduce an error in velocity profile. On the other hand a much larger error is introduced by the accuracy of the GPS signal on which the in-vehicle speed profile is based. This signal contains quite a lot of noise that comes back in the speed profile of the in-vehicle observation.

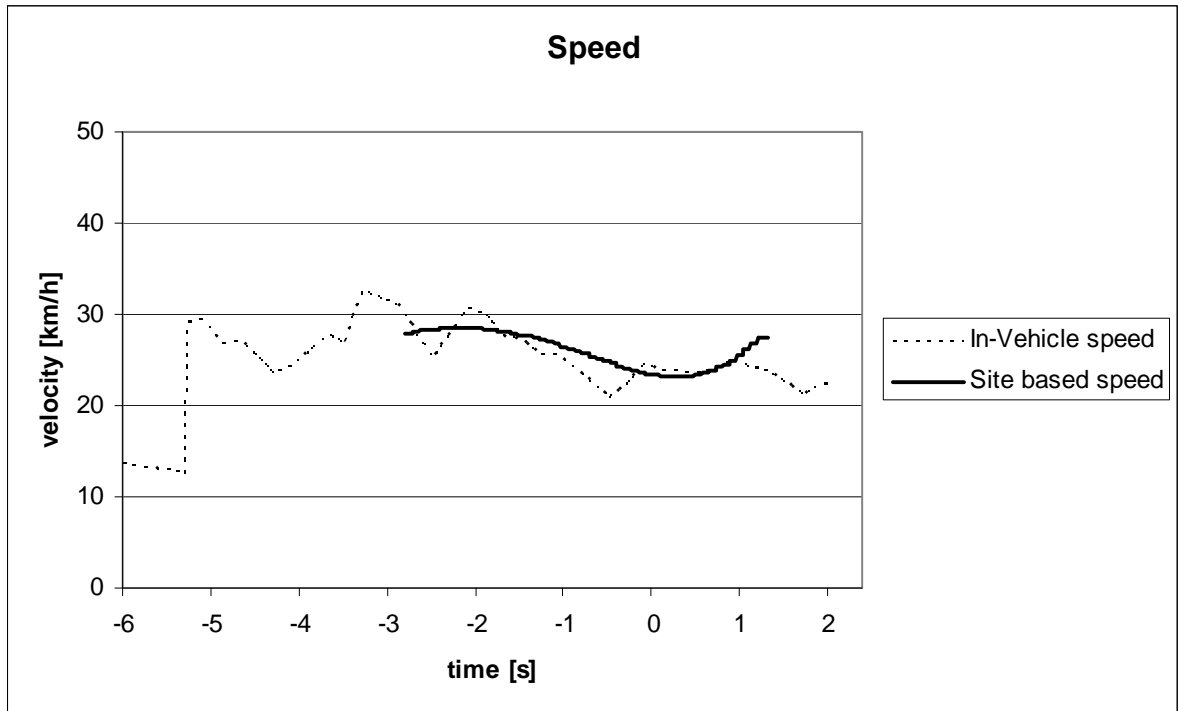

Figure 62. Combined in-vehicle and site-based speed of car taking a right turn at a green traffic light on June 3rd, 2010

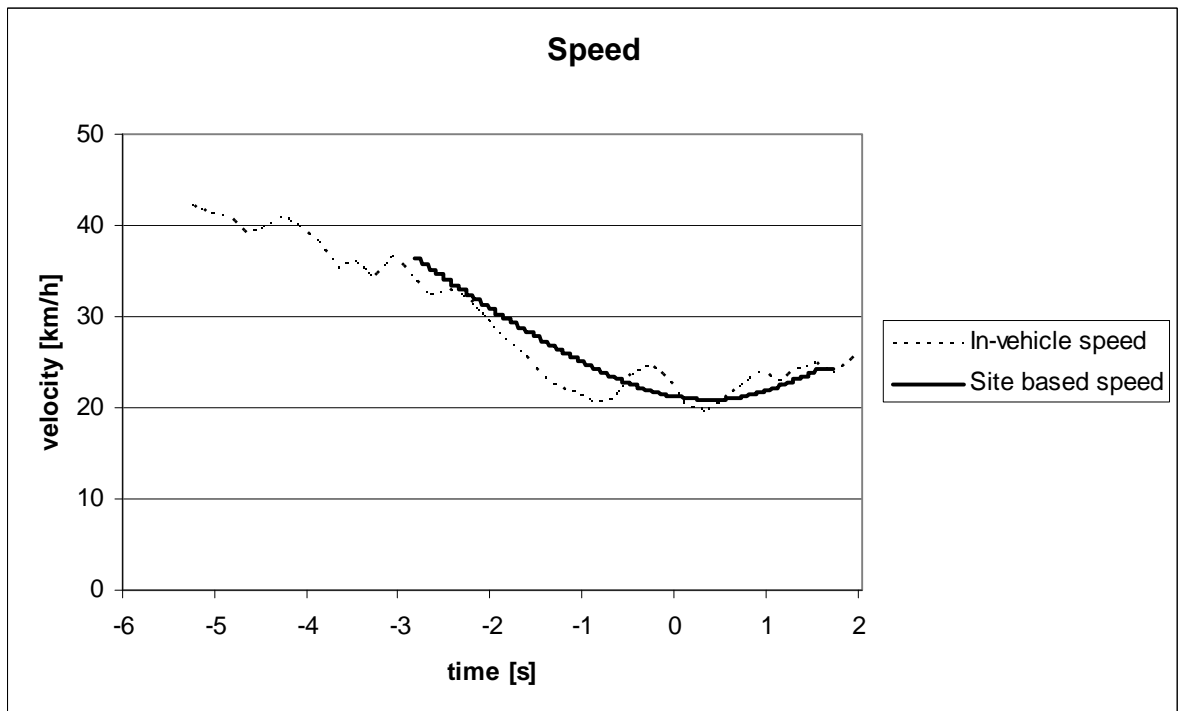

Figure 63. Combined in-vehicle and site-based speed of car taking a right turn at a green traffic light on June 4th, 2010

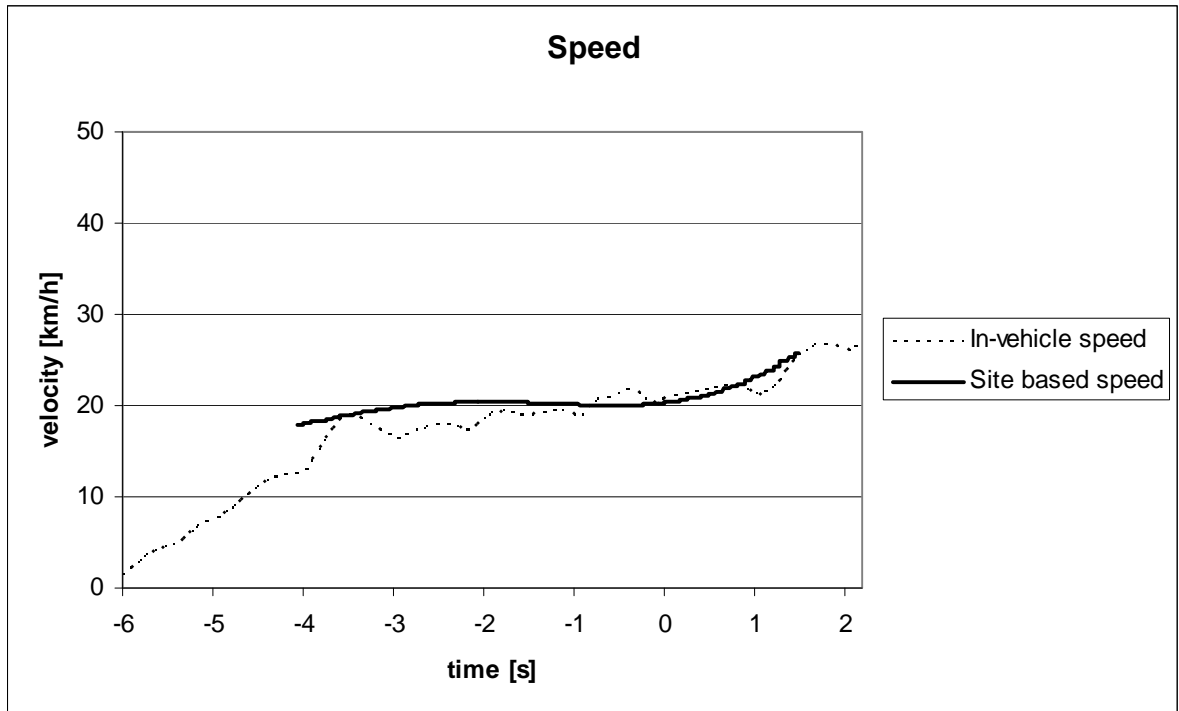

Figure 64. Combined in-vehicle and site-based speed of car taking a right turn at a green traffic light on June 7th, 2010

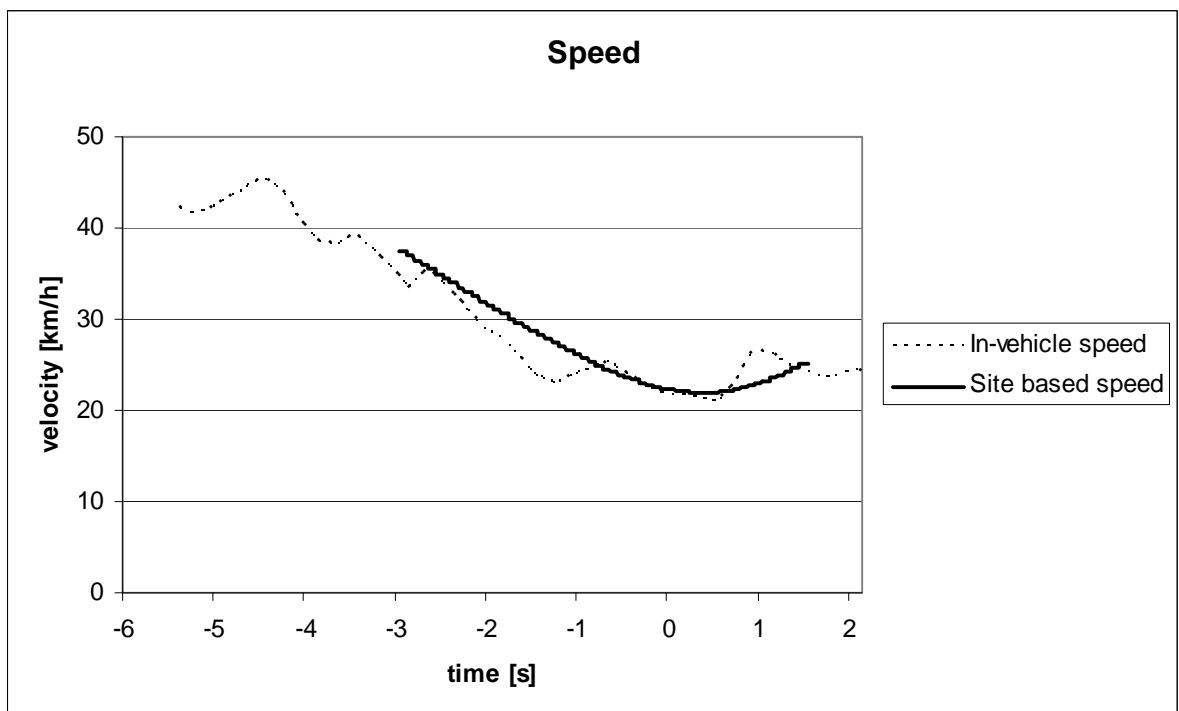

Figure 65. Combined in-vehicle and site-based speed of car taking a right turn at a green traffic light on June 8th, 2010

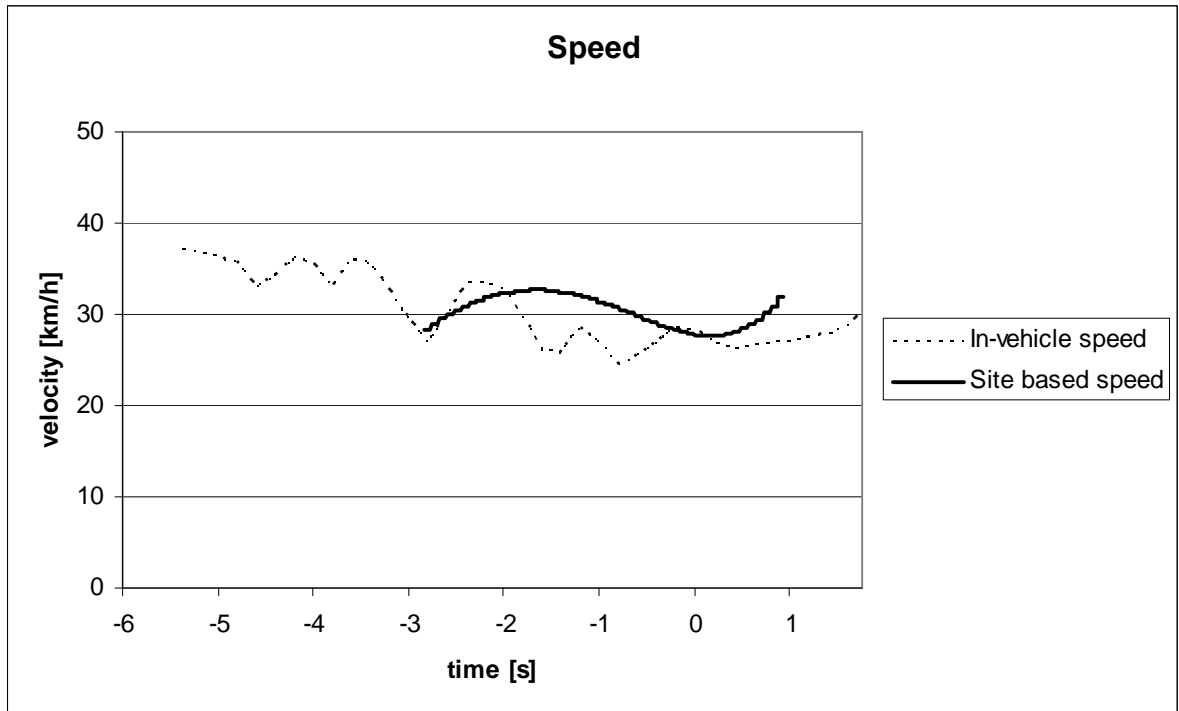

Figure 66. Combined in-vehicle and site-based speed of car taking a right turn at a green traffic light on June 11th, 2010

5 Summary & discussion

5.1 Site-based observation

5.1.1 Discussion of main results, insights and limitations

In this feasibility study automatic data processing of video data was compared to manual data processing. Furthermore, two traffic safety measures were considered, TTC and PET, to see if they could be determined from video data.

The manual processing was more accurate, but took a lot of processing time (a couple of days for one day of video data). The automatic processing was less accurate, but was much faster (15 minutes for one day).

Differences between Manual and Automatic processing that caused some small errors between the results of the approaches were:

1. The vehicles that turned right at the intersection included cars and trucks in the automatic processing, but not the manual processing. To determine the different types of road users extra filtering was needed.
2. In the automatic processing mopeds were also counted as cyclists, while in the manual processing these were excluded.
3. Targets behind other targets were sometimes not tracked or tracked twice in the automatic processing, because objects were merged to one (especially with cyclists) or suddenly the tracking switched between several objects counting objects twice.
4. Specifically when there was a group of bicyclists, the problem of visual overlap occurred and the separate bicyclists were merged to one object.
5. In the automatic processing, when an object becomes static, the object will be included into the background estimation and will disappear. When the object is moving again, there will be a ghost object at the position where it was standing still, because the background estimation differs from the real background.
6. To check the vehicles that turned right, a certain region (from the top view) was determined. If vehicles crossed this region, it was assumed that this vehicle turned right at the crossing. The accuracy of the automatic counting thus largely depended on the determination of this region. If the detection of a vehicle was not that accurate, the path of this vehicle could have been outside the detection region and thus was not counted as a vehicle turning right, although the vehicle actually turned right in reality. For the cyclists it was also seen that the cyclists sometimes did not follow the traffic rules, but drove against the traffic flow.

With respect to TTC and PET values, it can be concluded that the non-halted turning cars are more involved in conflicts with bicyclists than the cars that start from a halted position. Although the total number of non-halted encounters is rather limited, the general picture is that the minimum value of PETs and TTC's for the non-halted encounters is much lower than for the halted encounters. This can be explained by a specific feature in the signalization scheme with a pre-start for bicyclists at the beginning of the green phase.

5.1.2 Lessons learned and potential for up scaling

The results showed that with automatic processing it was sometimes difficult to determine the different road users. This caused sometimes bad counting results compared to the manual processing. Having a top view camera or more cameras with more viewpoints could improve this by providing the ability to detect the sizes of the road users

and therefore the road user type. This will also result in a proper determination of the road user's path, which is needed to calculate the correct travelling speed, the Time-To-Collision and the Post Encroachment Time.

Furthermore, automatic processing will only be useful if it is able to detect moving objects and objects standing still for a few seconds. Also, if there is a visual overlap, objects could be merged to one object. Having more cameras or other information like for example, loop detection, radar or laser scanner information could improve the accuracy of the traffic intensity.

These recommendations will improve the automatic processing accuracy and make it possible to derive traffic safety measures from large amounts of video data.

5.2 In-vehicle observation

5.2.1 Discussion of main results, insights and limitations

In the in-vehicle study, driving behaviour and interaction with cyclists at an intersection was analysed using the in-vehicle data. The aim was to assess if different driving behaviour was observed when vehicle drivers make a right turn manoeuvre in different conditions: halted versus non-halted and cyclist versus no cyclist. As the presence of cyclists at the intersection was derived from the site-based data, in the analysis of the in-vehicle data only two conditions were distinguished: halted versus non-halted. In the overall analysis in section 5.3 on combining the in-vehicle data and the site-based data, differences in driving behaviour between all four conditions were distinguished.

The results show that both direct and indirect glance behaviour increased in terms of duration and frequency in the halted situation compared to the non-halted situation. This supports the idea that vehicle drivers might adapt their driving behaviour and take safety measures to compensate for a less accurate mental image of the presence of cyclists. Additional support for this idea comes from the speed and lateral acceleration measures. Both speed and lateral accelerations are lower in the halted situation compared to the non-halted situation. Crossing the Conflict Area with a lower speed gives the vehicle drivers more time to look for cyclists that might be on a conflicting path.

Although the results seem to support the hypothesis, it is important to be aware of the limited reliability of these results. First, the total number of the specific right turn manoeuvres included in the analysis is small ($N=11$). A larger number of subjects would increase the reliability of the results. Second, the driving behaviour was observed on a single intersection. To ensure the observed behaviour was not induced by other features of the intersection, driving behaviour needs to be observed on multiple intersections. Finally, drivers' glance behaviour was coded manually by a single data coder. To increase the reliability of the glance behaviour data, several options are possible. Glance behaviour could be coded by multiple coders to assess inter-observer reliability. Another option would be to use technology (like an eye tracker or automated glance behaviour coding) to increase the reliability of the glance behaviour data.

Based on the results of the in-vehicle data, it can be concluded that vehicle drivers seem to show different driving behaviour when making the right turn manoeuvre from a halted situation compared to a non-halted situation. This could imply that drivers adapt their behaviour to the situation and compensate for the more dangerous situation by driving slower and looking more. Based on the results of this study it is not possible to conclude if the change in behaviour compensates sufficiently for possible differences in safety between the two situations.

5.2.2 Lessons learned and potential for up scaling

This paragraph discusses the lessons learned and the potential for up scaling of the in-vehicle trial. Each consecutive step of the study is evaluated and recommendations for up scaling are discussed.

Technology used

The technology used in a Naturalistic Driving study is of crucial importance for the successful performance of the experiment. The equipment has to operate autonomously and reliably and should not cause any discomfort, danger or change of behaviour to the subjects. Moreover, it should produce valid data in order to address the research questions of the study.

Power supply and switching between modes

One of the main lessons learned in the in-vehicle trial is the importance of a robust mechanism that regulates the power supply of the DAS. In the Dutch in-vehicle trial, power to the DAS was supplied directly from the vehicle's starter battery. The switching between the different power modes of the DAS, the different modes as described in Figure 11, was done on the basis of sensory data (GPS speed and accelerometer data). The described mechanism was not reliable and did not always correctly turn the DAS in the power safe mode when the vehicle wasn't used for a period of time. As a result, in eight cases participants experienced inconvenience due to a depleted starter battery.

The main reason that the DAS failed to correctly switch between the different power states had to do with inherent properties of the GPS signal. As described before, once the DAS was recording, it would stop recording if the detected GPS speed was below a certain threshold for a certain period of time. The problem encountered was that the GPS data, especially when stationary, was quite noisy. An example of this noise can be seen in Figure 67. For the first 87 seconds the vehicle was stationary, as the longitudinal acceleration was zero. Nevertheless, GPS speed was detected, even up to 6 km/h. As a result of this noise the DAS did not always switch to idle mode when the vehicle was parked. Based on this experience it is concluded that GPS data is not accurate enough for this purpose. It is recommended to develop a mechanism to switch between the different power states that is not based only on the GPS data.

Apart from the mechanism that switches between the different power states, the minimal amount of power the DAS consumes (in the low power state) is a point of consideration. In the configuration of the DAS as used in this trial, the power consumed by the DAS in the low power state depletes a vehicle's starter battery in approximately four days. As a precautionary measure, the DAS in this trial was set-up to turn off (no power used but user intervention needed to power up again) after 72 hours in the low power state (e.g. vehicle not used for three days). This happened a number of times and required involvement from the researcher to switch the DAS on again. To reduce the support time needed for the systems, it is recommended to develop a mechanism that doesn't require an intervention to switch back to the "power on" mode when the vehicle is used again.

Also, it is recommended to use a different power source for the DAS. It would be better to have a separate battery that will be charged by the vehicle's alternator, but cannot deplete the vehicle's starter battery. This would also prevent unexpected DAS behaviour, like a software crash, to deplete the vehicle's starter battery. This unfortunately happened a number of times.

To reduce the support time needed for the systems and discomfort for the participants, it is recommended to develop a mechanism that switches on and off autonomously and cannot deplete the car battery.

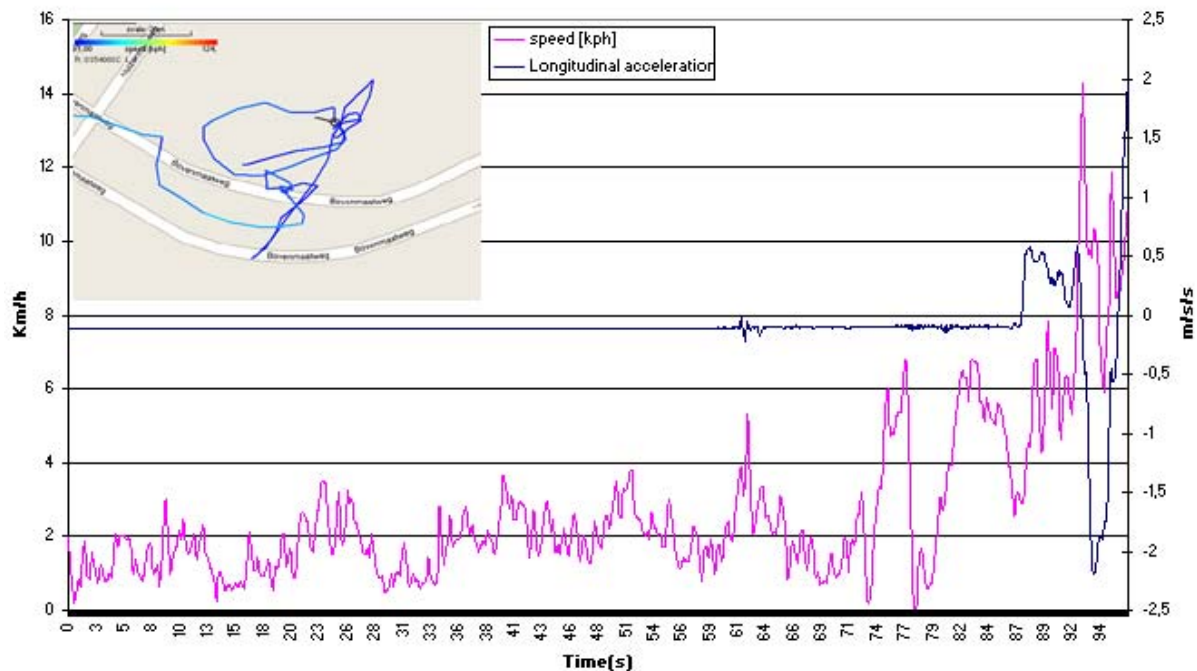

Figure 67. Illustration of stationary GPS data recorded by the Data Acquisition System

Accuracy of GPS data

Another consideration when selecting the DAS and sensors for a Naturalistic Driving trial is the technical specification of the DAS and its sensors. If the focus of the research questions requires measurements on a relatively small geographic area such as an intersection or (even more specifically) a particular conflict zone at an intersection, the data resolution and precision that a typical GPS receiver can offer might not be sufficient. A typical GPS receiver has a refresh rate of 1 Hz, meaning speed, location and other GPS-derived variables are recorded once per second. A high end GPS receiver can offer a refresh rate of 5 to 20 Hz. The typical accuracy in determining the geographical location is around 1 to 30 meters. In this trial, data segments of around seven seconds were analysed. The limited refresh rate and position accuracy of the GPS receiver is visible in the speed data derived from the GPS data in the seven second segments (Figure 68). In reality the speed curve is likely to be smoother.

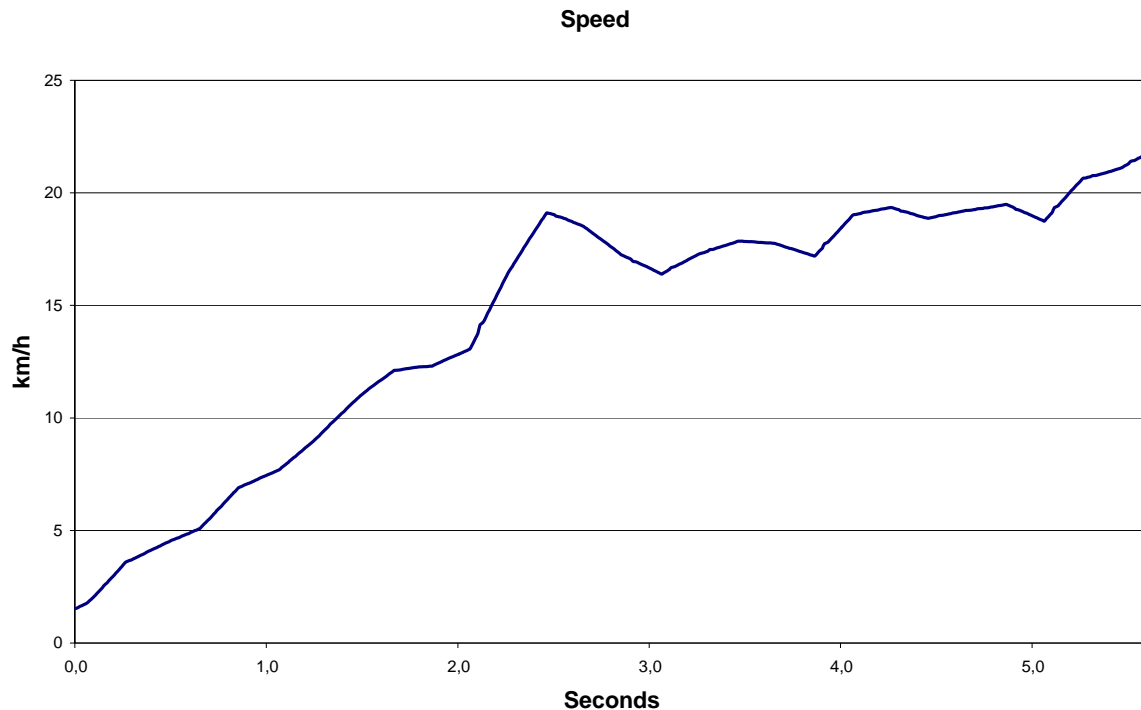

Figure 68. Illustration of GPS derived speed over a short period of time

Comparing GPS data with speeds derived from the three axis accelerometer

Theoretically, speed could also be derived from accelerometer data. The 3-axis accelerometer used in this trial offers data on accelerations of the moving vehicle on the X, Y, and Z axis according to a so called 3D Cartesian coordinate system. With the Pythagorean theorem in 3D ($R^2 = R_x^2 + R_y^2 + R_z^2$), the speed and direction of the vehicle were calculated. As the refresh rate of typical accelerometer is higher (up to 100 Hz) than the GPS data refresh rate, accelerometer data could be used to enhance GPS derived speed data.

The acceleration data derived from a typical accelerometer is however also affected by the Earth's gravitational forces. When the accelerometer is tilted (but stationary) for example, an acceleration is detected. In other words, a stationary vehicle on a slope (tilted) and a vehicle accelerating on a flat surface could result in the same accelerometer data. Speed that would be calculated only on the basis of 3-axis accelerometer data is affected by this phenomenon (Figure 69). The effect of Earth's gravitational forces on accelerometer data could be compensated for by combining data from an accelerometer and gyroscope (often offered combined in a single sensor). Combined data of an accelerometer and gyroscope offer six degrees of freedom (6DoF) (forward/backward, up/down, left/right motion and rotation about the three perpendicular axes: pitch, yaw, roll). The combination of an accelerometer and gyroscope is often referred to as an inertial measurement unit (IMU). When high resolution velocity and position data are needed, the use of a sensor combining an accelerometer and gyroscope, to enhance the GPS derived data, is recommended.

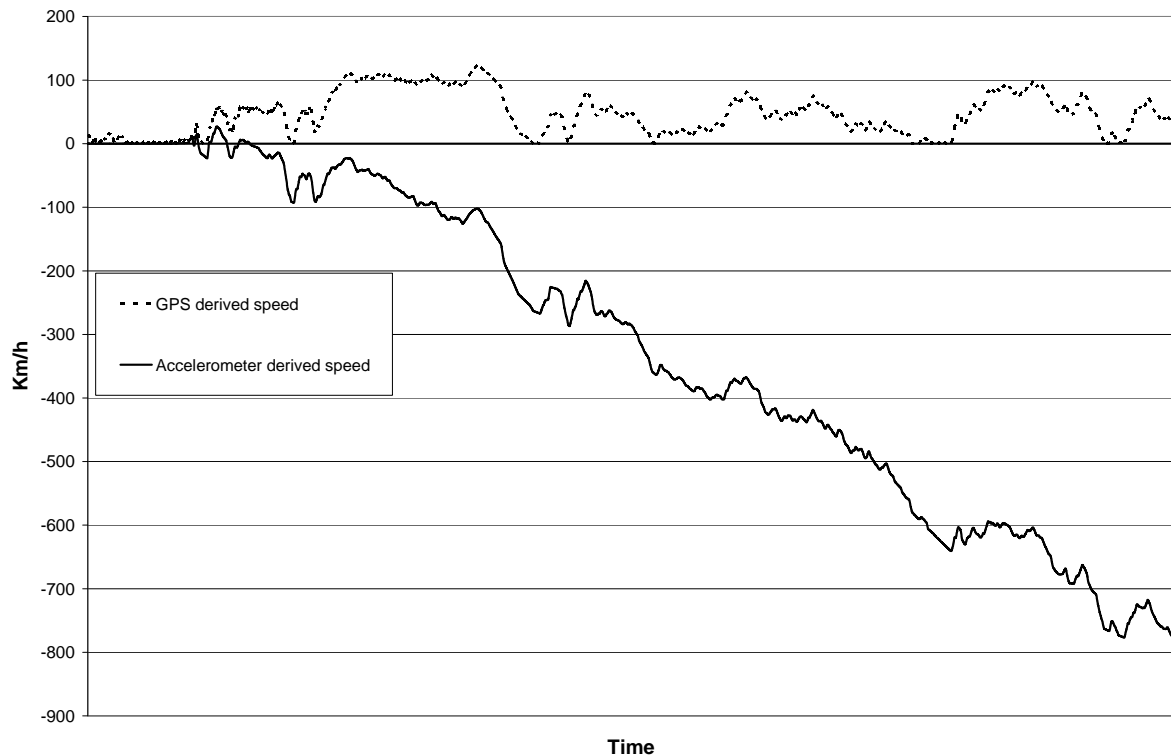

Figure 69. Illustration of difference between GPS derived speed and speed derived from a three axis accelerometer.

Data Acquisition System installation

Although the DAS used in this trial was relatively easy to install, the DAS had to be installed in the participants' vehicle by professionals. The main reason for hiring professionals was the permanent power connection that had to be made to the vehicle's starter battery in order to supply power to the DAS. Intervening in the vehicle's electrical system could cause liability issues when not done by professionals. Because subcontracting can be expensive, the amount of time and the level of skills needed by professionals for installing a DAS and peripheral sensors should be considered when selecting or developing a DAS for a Naturalistic Driving study.

As for the installation of the cameras, it could be advisable to measure the exact location and orientation (angle) of the cameras in the vehicle. In this trial for example, the event of entering the *Area Of Interest* was estimated on the basis of the video data (Figure 47). This estimate could have been enhanced if the exact location and orientation of the camera in the vehicle was known. With this information, for example, the exact distance of the camera to an object in a specific video frame could be determined. Once this distance is known, other distances could be derived on the basis of the vehicles measurements and the camera's location in the vehicle, like the distance from the object to bumper of the vehicle. If these measurements are required, secure mounting and possible periodic recalibration of the cameras would be required.

Data retrieval and data handling

In this trial data was retrieved on a regular basis on the premises of the company where the participants worked. For this small scale trial, the procedure followed proved to be comfortable for both the participants and the researcher retrieving the data. On a field trial of larger scale and with participants not all concentrated in one location, this

procedure will be labour intensive and expensive. It is recommended to aim for a lower frequency of the data retrieval. To achieve this, a larger data storage device is needed. But it is not only the size of data storage; the reliability of the system is also important. In this trial, the data retrieval activity was also used to check the correct functioning of the DAS and the mounting of the cameras. In quite a few cases, intervention (e.g. re-setting the DAS) was needed to prevent loss of data.

For the Dutch in-vehicle trial, only a relatively small amount of data was analyzed. The amount of time spent on data handling however was relative large. The conversion, selection of the right segments and preparation for analysis all took a lot of time. For the data handling on a large scale trial, sophisticated software should be available or developed to reduce the amount of time spend on data handling. The requirements of the software to address the research questions in an efficient way and the compatibility of the software with the DAS' data format, should be known beforehand in greatest detail possible. In the Dutch in-vehicle trial for example, video and sensory data were recorded when the participants crossed several predefined intersections. The (video) data segments however, were not labelled. It would be helpful if the file would have a label indicating *which* intersection was crossed. To select all the data for one specific intersection, a script had to be written. The execution of the script took the computer one day to process, whereas this is only a limited dataset of 8 vehicles. Altogether, the process of selecting the right data segments turned out to be much more time consuming than anticipated.

Conclusion

The performance of this in-vehicle trial provided useful knowledge and experience for developing a large scale Naturalistic Driving trial. As for the *technology used* the main lesson learned was the importance of a reliable power source for the DAS. Unforeseen irregularities in the mechanism that switch the DAS between different power modes should not lead to any discomfort for the participant (e.g. exhausted starter battery) and should minimize the amount of data lost. Additionally the specifications of the sensors used should match the criteria set by the research design. Because in most cases the DAS will need a permanent power supply (hardwired to the vehicle's electrical system), the installation of the DAS needs to be done by professionals. As subcontracting can be expensive, the amount of time and the level of skills needed from professionals for installing a DAS and peripheral sensors should be considered when selecting or developing a DAS for a Naturalistic Driving study. Finally, Naturalistic Driving studies can produce a large amount of data; in particular the video data makes it very large. Although the storage capacity of hard drives increased rapidly over the decennia, data will need to be retrieved from the vehicle on a regular basis which can be a time consuming activity. A well planned structure of the data and easy accessibility will facilitate the analysis and reduce the time needed to prepare the data for analysis. As manual video coding is very labour intensive, the amount of video coding should be minimised. In some cases extra sensors (e.g. an eye tracker) or automated video coding *tools (machine vision)* could reduce the amount of video coding needed.

5.3 The potential of combining site-based and in-vehicle observations

The objective of this study was to explore the value and feasibility of combining the two naturalistic observation methods: site-based observation and in-vehicle observation. This paragraph discusses value of the combining the two observation methods and the potential for up scaling.

5.3.1 Discussion of main results, insights and limitations

The value of combining the two observation methods is twofold. At first it offers the opportunity to enrich the information from one study with complementary observations from the other study. Secondly, it offers the opportunity to *validate* measures from the individual studies.

The first value identified was the opportunity to enrich the information of one study with the complementary observations from the other study. In this study the site-based data was used to identify whether a cyclist was present or not. The in-vehicle data was not accurate enough to clearly identify the presence of a cyclist based on a strict definition. To study the question regarding the difference in driving behaviour when making a right turn, measures from the two studies were combined. The PET and TTC values from the site-based observation, and the speed behaviour and looking behaviour from the in-vehicle observation. These variables together allowed us to develop a more comprehensive picture of the safety of driving behaviour. Overall, the results indicate that drivers adapt their behaviour to the more dangerous situation by reducing speed and looking more.

These results are only indicative as the number of overlapping cases was small. During the two weeks of site-based camera observation, 5 cars equipped with in-vehicle DAS took a right turn at the specified intersection. These were all non-halted situations. This was less than expected. When setting up the study, it was aimed to create a situation in which the in-vehicle equipped cars would pass the equipped intersection regularly in their natural driving. By selecting an intersection close to the working place of the in-vehicle participants, it was anticipated to obtain a considerable amount of overlapping data from the site-based cameras and the in-vehicle equipment. However, the majority of the participants turned out to take a different route as anticipated. These participants did cross the intersection, but did not make the right turn that was anticipated but instead they crossed the intersection straight. This reduced the number of overlapping cases significantly.

With regard to the difference between halted and non-halted vehicles, we learned that the automatic video detection of road users is based on detecting moving objects with respect to a fixed background. Therefore vehicles that stand still, i.e. a speed of 0 km/h, are not detected. So, the definition of a halted vehicle had to be adjusted during the study to a low speed (below 20 km/h), as vehicles that stopped for a red light and just accelerated to take a right turn. These vehicles were counted as vehicles that made a right turn from a halted position.

On the specific intersection that was observed in this study, not many conflicts between vehicles and bicycles were detected. Conflicts were only possible when the vehicles turning right came from a non-halted situation (i.e. they did not have to wait for a red traffic light), although vehicles and bicycles had to react to the same traffic light and had a green light at the same time. This was due to the fact that the halting place in front of the traffic light of the bicycles was 3 meters further ahead of the halting place of the vehicles. In this way the bicycles were ahead of the vehicles when starting off at a

green traffic light. This infrastructural situation turns out to be very effective in the prevention of conflicts.

The second value identified was the opportunity to validate the measures from the individual studies. In this study the 5 overlapping cases were used to compare the speed profiles from the two observation methods. For these right turn manoeuvres the results of the site-based and in-car measurement of speed were compared. For the site-based measurement the manually derived speed profiles were taken into account. The comparison of speed profiles from the two different observation methods showed that the velocities of the site-based and in-vehicle have a similar profile. However, differences between the profiles are visible. This difference can be explained on the one hand by a small error that is introduced when, during manual tracking of the site-based observation, not the exact wheel centre is selected. After transformation into world coordinates this can introduce an error in the velocity profile. On the other hand a much larger error is introduced by the accuracy of the GPS signal on which the in-vehicle speed profile is based. This signal contains quite a lot of noise that is clearly visible in the speed profile of the in-vehicle observation.

5.3.2 Lessons learned and potential for up scaling

In the “standard” in-vehicle naturalistic observation approach detailed information can be gathered from the driver and the vehicle, but the information about other road users, especially vulnerable road users, is limited. A site-based data collection with video cameras installed at specific locations could complement in-vehicle studies by being able to observe all the traffic passing at a given road location, including vulnerable road users such as bicyclists and pedestrians. In addition to in-vehicle observations, much can be learned from this approach with respect to what is going on at an intersection in the interaction between road users. It enables a detailed analysis of both parties involved in encounters and mutual interactions among road users.

This study showed that each type of study has its unique values. From in-vehicle data it is possible to look in detail at the driving behaviour of the participants over time and in different natural situations. The video data allows looking over the shoulder of the driver and observer where drivers are looking or what they are paying attention to. By analyzing their glancing behaviour, we know when and how often drivers look at other vulnerable road users to estimate their position and speed and to be able to anticipate.

From the site-based video data information can be added about the position and speed of other road users surrounding the participant's vehicle. Also the site-based data could provide information about how other drivers, non participants of the in-vehicle study, behave at that particular site. This allows relating the behaviour of the participant to the behaviour of non participants, which could be used for the generalizability of the results.

The overlapping speed profiles from the in-vehicle or the site-based data show that these data sources are reasonably comparable. This is an indication of the validity of each of the measures.

For a future large scale naturalistic driving study it could be valuable to add a number of sites with site-based observation. Two main areas are identified that would benefit from these complementary observations. One research area is when studying the interaction between drivers and vulnerable road users. Another research area that would benefit from the complementary observations is research questions related to infrastructure – as these are by nature related to a specific site like an intersection, a lane merge or a roundabout. The site-based observation allows to observe the traffic flow, the in-vehicle observation could add (for the overlapping cases) information on looking behaviour or other in-vehicle behaviours as well as additional vehicle data like accel-

erations. As Gordon (2006) states, major aspects of driver behaviour can be inferred from vehicle motions – decisions and timing, delayed reactions, risk taking, control accuracy, etc. Multi-vehicle interactions resulting from those actions can be extracted, visualized and understood. Site-based observations form an ideal data resource for modelling the driver-vehicle system interacting with other vehicles and the road. Combined with in-vehicle observations it enables a thorough understanding of the underlying processes in the success or failure factors in modern-day road traffic.

When setting up such a large scale study, it is extremely important to carefully define the overlapping cases required and to carefully select the participants and the sites in relation to each other to make sure the required cases will be obtained.

In general, traffic safety is a matter of *interactions* among road users (including vulnerable road users). These interactions are best studied in a combined study of site-based and in-vehicle DAS.

6 References

Gatscha, M., Brandstätter, C. & Pripfl, J. (2010). Report on field trial in Austria. PROLOGUE Deliverable D3.3. SWOV Institute for Road Safety Research, Leidschendam, The Netherlands.

Gordon, T. (2006). Video-based vehicle-tracking – Lessons from SAVME and new opportunities in naturalistic data collection. Second SHRP 2 Safety Research Symposium, August 16-17, 2006. Washington, D.C.

Hayward, J.C. (1972). Near-miss determination through use of a scale of danger. Highway Research Record, 24-34

Horst, A.R.A. van der, Rook, A.M., Amerongen, P.J.M. van & Bakker, P.J. (2007). Video-recorded accidents, conflicts and road user behaviour: Integral Approach Analysis of Traffic Accidents (IAAV). (TNO Report TNO-DV 2007 D154). Soesterberg: TNO Defence, Security and Safety.

Horst, A.R.A. van der (1990). A time-based analysis of road user behaviour in normal and critical encounters (Ph.D. thesis). Delft, The Netherlands: Delft University of Technology.

Kraay, J.H., Horst, A.R.A. van der & Oppe, S. (1986). Handleiding Conflictobservatietechniek DOCTOR (Report R-86-3). Leidschendam: Institute for Road Safety Research SWOV. (Report IZF 1986 C-6). Soesterberg: Institute for Perception TNO.

Appendix I: Informed consent

Overeenstemming betreffende medewerking aan onderzoek

Onderzoeksinstituut: Stichting Wetenschappelijk Onderzoek Verkeersveiligheid (SWOV) Naam van het onderzoeksproject: PROLOGUE Naam van de verantwoordelijk onderzoeker: Dr.Ir. Nicole van Nes
--

Doel van het onderzoek

Het belangrijkste doel van het Europese onderzoeksproject PROLOGUE (PROmoting real Life Observation for Gaining Understanding of road user behaviour in Europe) is het aantonen van het nut en de haalbaarheid van een grootschalig Europese Naturalistic Driving studie. In zo'n zogenaamde 'Naturalistic Driving' studie worden bestuurders geobserveerd in hun eigen auto en tijdens hun normale gebruik. Deze methode biedt de mogelijkheid om het gewone of natuurlijke gedrag van mensen te observeren, in normale omstandigheden alsook in eventuele (bijna) ongevallen. De verwachting is dat dit nieuwe inzichten kan opleveren over het rijgedrag van bestuurders in relatie tot elkaar en de omgeving. Dit zal naar verwachting leiden tot een beter inzicht in en begrip van verkeersonveiligheid en manieren om het verkeerssysteem inherent veilig te maken via bijvoorbeeld in-voertuig technologie, beter ontwerp van wegen, betere rijopleiding, etc.

In dit onderdeel van het onderzoek wordt een kleinschalige proef uitgevoerd om te kijken of een grootschaligere proef haalbaar zou zijn. De verzamelde data wordt met name gebruikt om te kijken welke analyses er mogelijk zijn en welke inzichten hiermee kunnen verworven.

In het project PROLOGUE werkt de SWOV samen met TNO (afdeling Menselijk gedrag in het verkeer). TNO doet een onderzoek waarin het gedrag op kruispunten wordt geobserveerd. Hiertoe zullen twee kruispunten in Zeist en omgeving door TNO worden ugerust met observatie apparatuur. SWOV en TNO zullen samen kijken naar de meerwaarde van de combinatie van de twee verschillende observatiemethoden en de mogelijkheid om de data te combineren.

Voorwaarden en procedures

Om uw rijgedrag te kunnen observeren wordt een tweetal camera's gemonteerd (een op de bestuurder gericht en een naar buiten gericht) en kastje voor de opslag van de gegevens in uw auto. Wij zullen deze apparatuur zodanig installeren dat er geen schade aan uw voertuig ontstaat. Mocht er toch schade door de installatie van de apparatuur aan uw auto ontstaan, dan zal de SWOV u schadeloos stellen.

Wij willen u vragen om te rijden zoals u dat normaal gewend bent. U hoeft geen extra handelingen uit te voeren of een ander rijgedrag aan te meten. U heeft ook geen extra ritten te maken voor het onderzoek. De observatieapparatuur werkt volledig automatisch, u hoeft het systeem dus ook niet aan of uit te schakelen wanneer u gaat rijden.

Om deel te nemen aan dit onderzoek dient u in het bezit te zijn van een geldig rijbewijs en uw auto dient WA verzekerd te zijn. Wij verzoeken u contact op te nemen met uw verzekeringsmaatschappij om er zeker van te zijn dat deelname aan dit onderzoek geen gevolgen heeft voor de verzekering van uw auto.

U geeft middels dit formulier toestemming aan de onderzoekers uw rijgedrag te observeren. Mocht het zijn dat u iemand anders in uw auto wilt laten rijden, dan willen wij u vragen om deze eventuele andere bestuurders van uw auto te informeren over dit onderzoek en het formulier 'Geïnformeerde toestemming voor medewerking aan onderzoek door incidentele bestuurder' te laten lezen en ondertekenen en dit naar ons op te sturen middels bijgevoegde enveloppe. Eventuele andere bestuurders van uw auto dienen geïnformeerd te zijn over de proef en dat er gegevens over hem of haar opgeslagen worden.

Indien iemand het formulier niet wilt ondertekenen en u wilt deze persoon toch graag in uw auto laten rijden, vragen we u het formulier 'verzoek voor verwijdering data' in te vullen en op te sturen of de datum, starttijd en eindtijd van deze rit te mailen naar de contactpersoon. Het is niet mogelijk de apparatuur op afstand uit te zetten, maar de betreffende data wordt dan zonder inzage verwijderd.

Wanneer er tijdens de duur van het experiment aanwijzingen zijn dat uw rijgedrag een extreem gevaar voor de verkeersveiligheid vormt, behouden wij ons het recht voor u uit te sluiten van verdere deelname aan het experiment.

Risico's en ongemakken

De observatieapparatuur die in uw auto wordt geïnstalleerd, is zodanig ontworpen dat u er tijdens het rijden niets van zult merken. De camera's worden zodanig geïnstalleerd dat ze u op geen enkele wijze het zicht zullen belemmeren.

Het kastje waarin de videobeelden worden opgeslagen wordt onder de stoel van de bestuurder of in de kofferbak gemonteerd. De enige elektrische verbinding die met uw auto wordt gemaakt zal door een professioneel garage bedrijf worden gemaakt. De aanwezigheid van de observatieapparatuur zal op geen enkele wijze interfereren met de normale functionaliteit van uw auto of met de normale gang van zaken wanneer u de auto bestuurd. Daarnaast wordt de observatieapparatuur zodanig gemonteerd, dat in het onverhoopte geval van een ongeluk geen gevaar van verwonding door de apparatuur bestaat.

Omdat u in uw eigen auto rijdt, blijft u zelf verantwoordelijk voor eventuele schade voortvloeiend uit een ongeval. Het feit dat u deelneemt aan dit onderzoek, vormt voor u geen extra risico. U bent echter niet aansprakelijk voor schade aan de observatieapparatuur.

U blijft zelf verantwoordelijk voor eventuele schade of diefstal van persoonlijke bezittingen in geval van inbraak in uw auto. U bent echter niet aansprakelijk voor diefstal van de observatieapparatuur, indien de auto was afgesloten. We verzoeken u daarom de auto af te sluiten wanneer deze onbeheerd wordt achtergelaten.

Mocht u de auto gebruiken voor een dienstreis voor TNO, dan is eventuele schade net als normaal gedekt door de verzekering van TNO. TNO heeft ons gevraagd u te wijzen op de beperkingen van deze verzekering. De WA verzekering van TNO dekt geen schade veroorzaakt door een motorvoertuig. Eventuele schade wordt alleen gedekt door de eigen autoverzekering. Eventuele casco schade is niet gedekt door de TNO verzekering, deze schade wordt gedekt indien uw auto allrisk verzekerd is.

Voordelen

Door uw deelname draagt u bij om het rijgedrag van automobilist beter te begrijpen. Inzichten uit dit onderzoek worden gebruikt voor verbetering van de verkeersveiligheid.

Betaling voor deelname

U ontvangt voor uw deelname aan dit onderzoek een bedrag van 100,- Euro. Indien u voortijdig met het onderzoek stopt ontvangt u 25,- euro indien u minimaal 1 maand heeft deelgenomen. De vergoeding wordt na afloop van de proef overgemaakt op uw bankrekening.

Vertrouwelijkheid

Inzage en verwerking van persoonlijke informatie over u, verzameld tijdens dit onderzoek is alleen voorbehouden aan de betrokken onderzoekers. Resultaten uit dit onderzoek kunnen worden gebruikt in wetenschappelijke publicaties. Resultaten zullen te allen tijde anoniem gepubliceerd worden zodat dat u niet kunt worden geïdentificeerd op basis van deze publicatie. Uw gegevens worden beheerd volgens de bepalingen voortkomend uit de Wet bescherming persoonsgegevens (Wbp).

Persoonlijke informatie over u verzameld tijdens dit onderzoek zal in geen geval aan derden worden overgedragen, tenzij de SWOV hiertoe wettelijk is verplicht (bv politie).

U heeft het recht om (een deel van) de opgenomen data door ons te laten verwijderen. Indien u dit wilt, vul dan het bijgevoegde formulier 'Verzoek tot verwijder van data' in en stuur het op naar de contactpersoon (uw kunt gebruik maken van de bijgeleverde enveloppe) of mail deze gegevens naar de contactpersoon.

Weigering of terugtrekking

Uw deelname aan dit onderzoek is op vrijwillige basis. Er is geen sprake van een boete wanneer u weigert deel te nemen. U kunt op ieder gewenst moment, zonder opgaaft van redenen, uw deelname beëindigen.

Contactpersoon

Uw contactpersoon voor dit onderzoek is:

Michiel Christoph

Email: Michiel.Christoph@SWOV.nl

Telefoonnummer: 070 – 3171174

Wij vragen u contact op te nemen wanneer:

- u het vermoeden heeft dat er iets mis is met de observatieapparatuur
- u betrokken bent geweest bij een ongeval
- u door omstandigheden niet verder kunt deelnemen aan het onderzoek

Ook voor andere vragen met betrekking tot het onderzoek kunt u contact opnemen met bovengenoemd persoon.

Verklaring

- Ik bevestig dat ik bovenstaande informatie heb gelezen en begrijp en stem in om deel te nemen aan het hierboven omschreven onderzoek .
- Ik ben in bezit van een geldig rijbewijs.
- Mijn auto is WA verzekerd en mijn verzekeringsmaatschappij heeft aangegeven dat deelname aan dit onderzoek geen gevolgen heeft voor de verzekering.
- Ik heb de mogelijkheid gehad om over de bovenstaande informatie na te denken en waar nodig vragen over te stellen aan de proefleider en heb voldoende tijd gehad om deze beslissing te kunnen nemen.
- Ik begrijp dat deze informatie wordt verwerkt door personen die werkzaam zijn bij de Stichting Wetenschappelijk Onderzoek Verkeersveiligheid (SWOV) te Leidschendam, voor zover zij deze nodig hebben voor een goede uitvoering van het hierboven vermelde onderzoek.
- Ik begrijp dat mijn deelname aan dit onderzoek op vrijwillige basis is en dat ik op ieder moment vrij ben mijn deelname te stoppen zonder opgaaf van redenen en zonder consequenties.
- Ik heb de in de auto gemonteerde apparatuur gezien en bevestig dat dit geen invloed heeft op de uitvoering van de rijtaak.
- Ik begrijp dat ik eventuele andere bestuurders van mijn auto dien te informeren over dit onderzoek en het formulier 'overeenstemming betreffende medewerking aan onderzoek' zal laten lezen en ondertekenen en dit naar op te sturen naar de SWOV.
- Ik accepteer de voorwaarden en risico's zoals beschreven in dit document en zal geen claim indienen richting SWOV of TNO in geval van schade door ongeval of inbraak.

Naam proefpersoon

Naam onderzoeker

Bank/giro nummer

Tnv

Datum

Datum

Handtekening

Handtekening

List of Figures

Figure 1. Illustration of relation between site-based observation and in-vehicle observation.	10
Figure 2. Illustration of potential conflict between vehicle and cyclist	11
Figure 3. Picture of the intersection in the village of Zeist. The white dot indicates the location of the cameras.	15
Figure 4. Photos of the two cameras in the lamp post.	15
Figure 5. Views of both cameras.	16
Figure 6. Screen shot of the TNO CarTracker software tool.	17
Figure 7. Overview of the pdrive data acquisition system	18
Figure 8. Illustration of recorded video data.	19
Figure 9. Illustration of camera setup	20
Figure 10. Illustration of location based event triggers	21
Figure 11. Overview of different operating modes of the Data Acquisition System	22
Figure 12. Illustration of file and folder structure of data recorded by the DAS.	23
Figure 13. Illustration of the analysis software	23
Figure 14. Dat-file output of CarTracker.	25
Figure 15. Coordinate transformation, video pixels	26
Figure 16. Coordinate transformation, GPS	26
Figure 17. Coordinate transformation, world	27
Figure 18. Path of a car taking a right turn tracked by hand by the wheels on the left side of driver.	28
Figure 19. Path of car taking a right turn in world coordinates.	28
Figure 20. Tracked, interpolated and polynomial curve fit on tracked coordinates of the front left wheel of a car taking a right turn	29
Figure 21. Tracked, interpolated and polynomial curve fit on tracked of car taking a right turn, front and rear left wheels (x- and y- world coordinates)	29
Figure 22. Yaw angle of a car taking a right turn.	30
Figure 23. Bounding box around car taking a right turn	31
Figure 24. Bounding box of a car which is taking a right turn	31
Figure 25. Velocity profile for car taking a right turn	32
Figure 26. In-car equipped vehicle enters conflict area	32
Figure 27. Velocity profile of in-car equipped vehicle wrt conflict area	33
Figure 28. Visualisation of PET ($t_2 - t_1$): the time it takes car2 to reach the point where both paths cross.	34
Figure 29. PET: t_2 is the moment that the car (blue boxes) enters the path of the cyclist (red boxes).	34
Figure 30. PET: t_1 is the moment that the cyclist (red boxes) leaves the path of the car (blue boxes).	35
Figure 31. Potential conflict, car taking a right turn and cyclist is crossing the intersection	36
Figure 32. TTC: car and cyclist are synchronised and first extrapolation is performed	36
Figure 33. TTC: extrapolation is performed on more tracked data	37
Figure 34. TTC: extrapolation is performed and a collision occurs.	37
Figure 35. Left picture: Car turning right. The car is the moving object that has to be detected. Right picture: By subtracting the video frame from the background estimation, the foreground pixels will be visible (in blue), because the background remains the same.	39
Figure 36. The moving object, which is enclosed by the red bounding box.	39
Figure 37. The tracking point of each road user was chosen to be the bottom left point of the bounding box for defining the travelled path (red line). This will give an error with respect to the real travelled path (green line).	40

Figure 38	Examples of travelled paths of different road users.	41
Figure 39	Examples of travelled paths of several road users converted to the earth coordination axes in meters (Background figure was taken from Google Earth).	42
Figure 40	Selected paths (red) for vehicles that crossed the selected region (red square) and were considered as turning right at the intersection.	43
Figure 41.	Two camera's mounted with suction mounts behind the rear view mirror.	46
Figure 42.	The Data Acquisition System installed under the driver's seat	46
Figure 43.	Tinted foil applied to the windscreen to obscure the camera mounts.	47
Figure 44.	Magnetic white "dot" applied to the roof	47
Figure 45.	Illustration of intersection and the right turn manoeuvre	49
Figure 46.	Illustration of the Area Of Interest (AOI) (highlighted area) and the Conflict Area (CA) (hatched area).	50
Figure 47.	Upper left: reference point for entering the Area of Interest. Upper right: reference point for leaving the Area of Interest. Lower left: reference point for entering the Conflict Area.	52
Figure 48.	Illustration of glance behaviour analysed	53
Figure 49.	Total number of cars that turned right for Manual and Automatic processing	55
Figure 50.	Total number of cars that turned right for Manual and Automatic processing	55
Figure 51.	Number of cars turning right that had green light for manual and automatic processing	57
Figure 52.	Number of cars turning right that had red light for manual and automatic processing	58
Figure 53.	Total number of cyclists that crossed the path of the right turning cars for Manual and Automatic processing	59
Figure 54.	Number of encounters between non-halted cars and cyclists for manual and automatic processing	60
Figure 55.	Number of encounters between halted cars and cyclists for manual and automatic processing	61
Figure 56.	Difference in speed estimation for manual and automatic processing for the instrumented vehicle that turned right on the intersection at June 8th at 07:55	62
Figure 57.	Car enters the conflict area (red rectangle)	63
Figure 58.	Velocity profile with regard to the conflict area	63
Figure 59.	Comparison of the Matlab calculations of PET values ('Matlab', n = 30) and the manually derived PET values from video by DOCTOR expert ('Manual', n = 53)	66
Figure 60.	Glance behaviour in relation to speed behaviour	69
Figure 61	Speed, acceleration and glance behaviour Graphs for six seconds before entering Conflict Area to exiting the Area Of Interest	71
Figure 62.	Combined in-vehicle and site-based speed of car taking a right turn at a green traffic light on June 3rd, 2010	73
Figure 63.	Combined in-vehicle and site-based speed of car taking a right turn at a green traffic light on June 4th, 2010	73
Figure 64.	Combined in-vehicle and site-based speed of car taking a right turn at a green traffic light on June 7th, 2010	74
Figure 65.	Combined in-vehicle and site-based speed of car taking a right turn at a green traffic light on June 8th, 2010	74
Figure 66.	Combined in-vehicle and site-based speed of car taking a right turn at a green traffic light on June 11th, 2010	75
Figure 67.	Illustration of stationary GPS data recorded by the Data Acquisition System	79
Figure 68.	Illustration of GPS derived speed over a short period of time	80
Figure 69.	Illustration of difference between GPS derived speed and speed derived from a three axis accelerometer.	81

List of Tables

Table 1. 2x2 research design and dependent variables of the in-vehicle and site-based observations	13
Table 2 Halted situation compared to non-halted situation.	13
Table 3 Cyclist present compared to no cyclist present.	14
Table 4 Overall extreme cases (non-hatched cells): cyclist present in halted situation compared to no cyclist present in non-halted situation	14
Table 5 Overview of sensors that can potentially be used with the pdrive data acquisition system.	19
Table 6 Overview of variables recorded in the Dutch in-vehicle trial.	19
Table 7. Points used for coordinate transformation	27
Table 8. Size of different road users	30
Table 9. Number of cars that turned right and the cyclists that crossed the intersection for manual and automatic processing on June 8th from 06:05 till 20:05	54
Table 10. Differences between manual and automatic counting	56
Table 11. Differences between manual and automatic counting for non-halted and halted vehicles	58
Table 12. Differences between manual and automatic counting of the cyclists	60
Table 13. Differences between manual and automatic counting for the encounters for non-halted and halted vehicles	61
Table 14. Mean and sd of cars entering the conflict area and the minimal velocity of the whole speed profile	64
Table 15. Total number of encounters by DOCTOR PET-categories as derived from the Matlab calculations and from manual inspection of the video images by a DOCTOR expert.	66
Table 16. Overview of glance behaviour in the halted and non-halted situation (1 standard deviation could not be calculated, mean based on single data point)	68
Table 17. Mean and standard deviation of speed, longitudinal accelerations and lateral accelerations when entering the Conflict Area for the Halted and Non-halted situation	68

List of Abbreviations

AOI:	Area of Interest
CA:	Conflict Area
DAS:	Data Acquisition System
ND:	Naturalistic Driving
PET:	Post Encroachment Time
TTC:	Time to Collision
DOCTOR:	Dutch Objective Conflict Technique for Operation and Research