



ACTIVE VIBRATION ISOLATION OF A RIGIDLY MOUNTED TURBO PUMP

T.G.H. Basten* and E.J.J. Doppenberg

TNO Science and Industry
P.O. Box 155, 2600 AD Delft, The Netherlands
tom.basten@tno.nl

Abstract

Manufacturers of precision equipment are constantly aiming at increased accuracy. Elimination of disturbing vibrations is therefore getting more and more important. The technical limitations of passive isolation methods require alternative strategies for vibration reduction, such as active techniques. In this paper active vibration isolation of internal vibration sources is considered. Due to static requirements, passive vibration isolation of such internal components can often not or hardly be achieved. As such an internal source a turbomolecular vacuum pump is considered. These pumps are applied in precision equipment applications where high vacuum is required and can for various reasons hardly be passively isolated from their environment.

A laboratory setup has been developed, based on a rigidly connected turbomolecular pump. The active system is based on adaptive feedforward/feedback control. The control performance and robustness are enhanced using an Internal Model Control scheme. The experimental setup and the control system will be described and initial results with tonal control will be discussed. It will be shown that with active vibration isolation substantial vibration isolation can be achieved leading to global vibration reduction.

INTRODUCTION

In precision equipment there is an ongoing need for increased accuracy. Manufacturers of high precision production machines and observation and imaging instruments are continuously aiming at increased resolution. Elimination of disturbing vibrations is therefore getting more and more important.

Traditional passive vibration isolation means introducing soft connections between the vibration source and the receiving structure. In practical situations, this

principle cannot always be applied or not in all transfer path directions. The technical limitations of passive reduction methods therefore require alternative strategies to effectively eliminate vibrations. Active vibration isolation is such a useful alternative.

Vibration sources which have to be isolated can be vibrating floors, but also internal vibration sources such as pumps, moving stages or electrical equipment. Due to static requirements, vibration isolation of such internal components can often not or hardly be achieved by passive means. In this paper a turbomolecular vacuum pump is considered as such an internal vibration source. These pumps are applied in precision equipment applications where high vacuum is required, such as electron microscopes. Generally, the pumps are connected close to the vacuum vessel because the attainable vacuum level decreases drastically with increasing distance. Moreover, the static forces due to the pressure difference between the inner and outer side of the system make it difficult to apply soft connections between the pump and the vessel. Passive vibration isolation, which is based on an impedance mismatch between the soft connection and the pump and vessel respectively, is therefore hardly achievable. Some suppliers of turbo pumps can supply a passive vibration isolator. However the isolation performance of these devices is mostly rather poor.

DEMONSTRATION SETUP

For experimental research to active isolation of turbomolecular pumps, a small laboratory setup has been developed, which is also suitable for demonstration purposes. The setup is based on a BOC Edwards turbomolecular pump (STP 451), which is rigidly connected to a small vessel. This vessel is suspended in an aluminum frame. The complete setup is depicted in Figure 1. The applied pump has electromagnetic bearings, making the vibration levels very low. However, due to the stiff connection between the pump and the vessel all remaining vibrations will be passed on to the vessel, without attenuation. The rated speed of the pump is 48,000 rpm, so a dominant vibration component can be expected at 800 Hz. Turbomolecular pumps cannot exhaust to atmosphere. Therefore an additional backing pump is used which is connected to the turbo pump via a very soft bellow. The vibrations of this backing pump are very well isolated in this way.

To enhance the vibration isolation via the connecting flange, anti-forces will be generated on the flange by means of proof-mass actuators. Electro-dynamic shakers (Motran IFX20-100) are applied for this purpose. Three actuators are connected to the flange between the pump and the vessel. Special connector blocks are designed, such that the actuators can be applied in various directions and positions on the flange. Accelerometers (type Endevco 50) are placed on the flange as error sensors for the control system. Another accelerometer, mounted on the pump, is used as reference sensor for the control system reference input. An independent performance sensor was applied on the vessel to measure and estimate the global performance of the active isolation system.

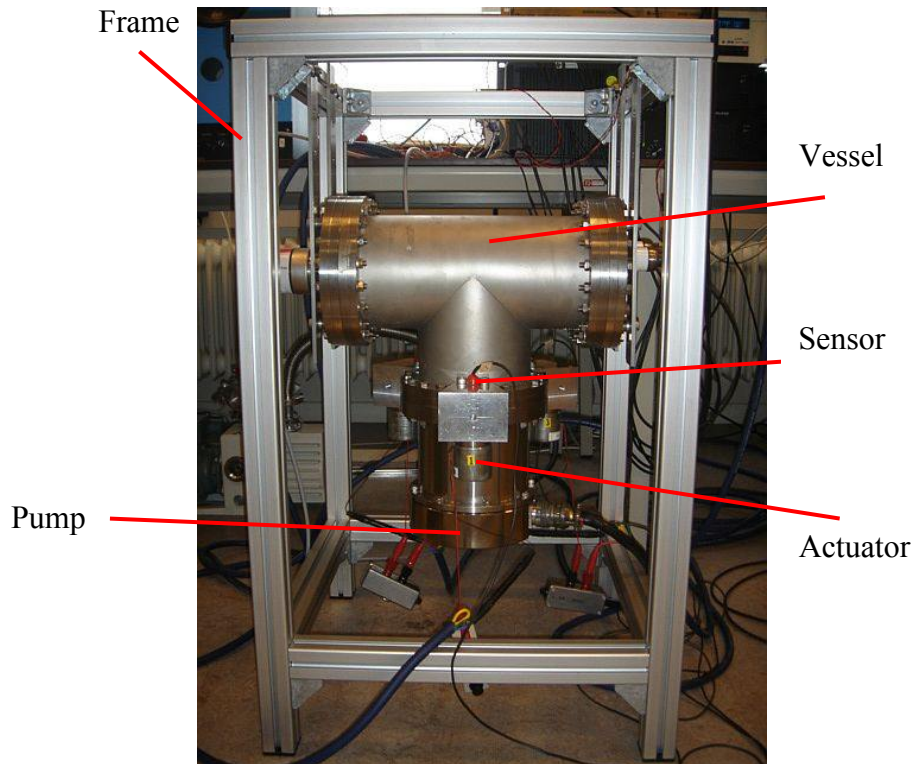

Figure 1 – Demonstration setup

THE CONTROL SYSTEM

The objective of the control system is actively enhancing the vibration isolation properties of the flange. In general the vibration isolation of the flange in 6 DOF should be considered. However in a preliminary study it was found that in the demonstrator setup the dominant vibration transmission path is in the vertical direction. This means that actively enhancing the isolation path in the vertical direction will reduce the vibrations of the vessel due to the vibration induced by the turbo pump.

To enhance the isolation in the vertical direction, the configuration of the actuators and sensors must be selected accordingly. In this case three proof mass actuators are mounted on the flange in the vertical direction. Three accelerometers applied as error sensors for the control system are also mounted vertically near the actuator position. With the defined control configuration, the main objective of the control system can be restated more precisely. The objective is minimizing the sum of the squared error sensor signals. The minimization is achieved by applying the appropriate dynamic forces on the flange in the vertical direction using the three proof mass actuators.

The proof mass actuators are driven by an adaptive multiple-input-multiple-

output (MIMO) feedforward control scheme. The feedforward control scheme needs a reference signal as a measure for the pump vibrations in the vertical direction. In this setup the signal of the accelerometer sensor, mounted vertically on the pump, is used as reference signal. Due to the rigid connection between the flange and the pump, there is a strong structural feedback from the actuators to the reference acceleration sensor. Without any countermeasure, the structural feedback will deteriorate the performance and robustness of the control system. To avoid deterioration of the control system, the control scheme is augmented to an Internal Model control (IMC) scheme.

Feedforward control with an Internal Model control scheme

The diagram depicted in Figure 2 is a schematic representation of an adaptive feedforward control with IMC scheme. In the diagram the contribution of the pump vibration to the error sensor signal $y(t)$ is modeled by:

$$y_{prim}(t) = x_{ref}(t) * h_{prim}(\tau). \quad (1)$$

The feedforward control needs the estimation of the reference signal $\hat{x}_{ref}(t)$ to cancel the vibration contribution $y_{prim}(t)$. The estimate of $\hat{x}_{ref}(t)$ is derived from the pump vibration signal $a_{ref}(t)$. Due to the rigid connection between the flange and pump, the pump vibration signal is ‘polluted’ with the actuator signal $u(t)$ via the structural feedback path $h_{ref,sec}(\tau)$. To reconstruct the signal $a_{ref}(t)$ properly, the pollution contribution $p_{ref}(t)$ must be cancelled with an Internal Model Control scheme.

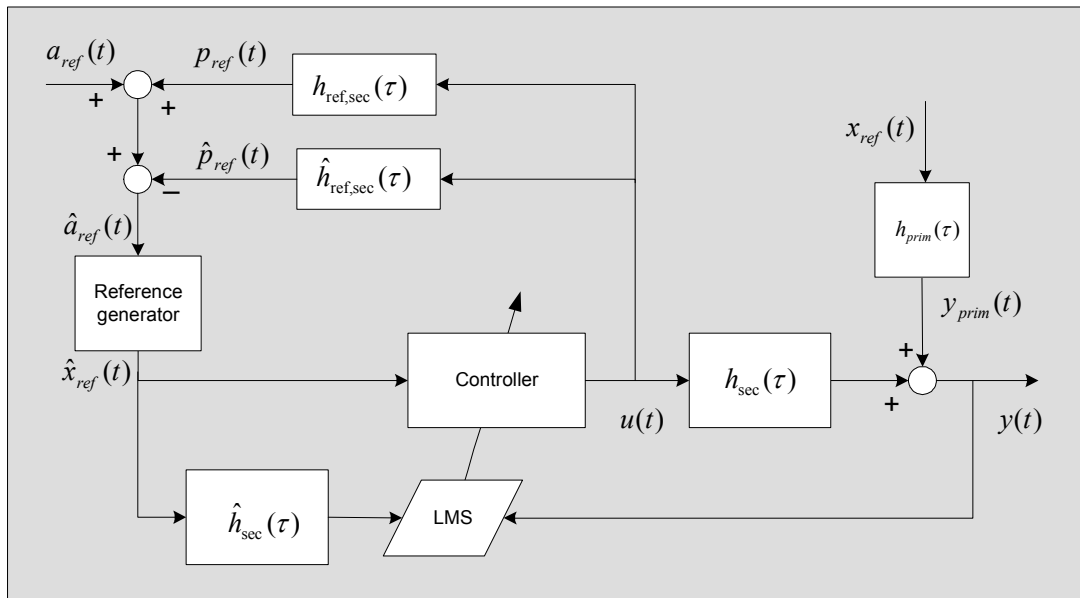

Figure 2 – Feedforward control with IMC correction

This is performed effectively by estimating and subtracting the pollution $\hat{p}_{\text{ref}}(t)$ from the pump vibration signal $a_{\text{ref}}(t)$. The estimated pump vibration signal becomes:

$$\hat{a}_{\text{ref}}(t) = a_{\text{ref}}(t) + u(t) * (h_{\text{ref,sec}}(\tau) - \hat{h}_{\text{ref,sec}}(\tau)). \quad (2)$$

If $\hat{h}_{\text{ref,sec}}(\tau) = h_{\text{ref,sec}}(\tau)$, the estimation is perfect ($\hat{a}_{\text{ref}}(t) = a_{\text{ref}}(t)$).

From the reconstructed signal $\hat{a}_{\text{ref}}(t)$ the reference signal $\hat{x}_{\text{ref}}(t)$ is generated using a dedicated reference generator, which is discussed later. For tonal control this reference signal will have tonal components, which are strongly correlated with the rotation frequencies of the pump.

For the feedforward control a filtered x-LMS control scheme is applied [1, 2], which uses an estimate of the secondary path $\hat{h}_{\text{sec}}(\tau)$ from the actuators to the error sensors (see Figure 2). To implement the IMC scheme an estimate $\hat{h}_{\text{ref,sec}}(\tau)$ of the structural feedback from actuator to reference sensor is needed. The estimations for the transfer functions $\hat{h}_{\text{sec}}(\tau)$ and $\hat{h}_{\text{ref,sec}}(\tau)$ are determined during an off-line system identification stage and are modeled as FIR filters.

The algorithm is implemented on a PC (AMD FX-55 CPU) and runs under Real Time Linux with an interface to Matlab. In the first stage tonal feedforward control is applied, aimed at reducing the tonal vibration component at the rotation frequency of the pump (around 800 Hz).

Reference generator

For tonal feedforward controller of rotating machinery often a tacho signal is applied, which is derived from a rotating shaft. In this case it is rather difficult to derive such a suitable tacho signal. Therefore the reference signal $\hat{x}_{\text{ref}}(t)$ is derived from the acceleration signal $a_{\text{ref}}(t)$ on the pump. This is performed in two stages:

1. Estimate the varying rotation frequency $f_{\text{ref}}(t)$ using a phase locked loop system [3].
2. Generate reference signal $\hat{x}_{\text{ref}}(t)$ from the varying rotation frequency $f_{\text{ref}}(t)$.

To derive and follow the slightly varying rotation frequency a phase locked loop algorithm is implemented, see Figure 3.

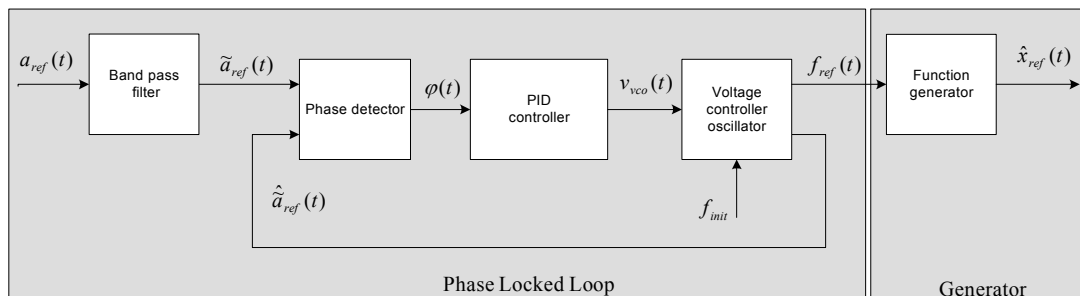

Figure 3 – Phase locked loop

The acceleration signal $a_{\text{ref}}(t)$ of the reference accelerometer is band-pass filtered for the frequency range around the fundamental frequency (± 800 Hz) of the pump. The phase detector detects the phase difference $\varphi(t)$ between the filtered signal $\tilde{a}_{\text{ref}}(t)$, and a periodic signal $\hat{\tilde{a}}_{\text{ref}}(t)$, which is generated by the voltage-controlled oscillator (VCO). On basis of the phase difference $\varphi(t)$, the frequency of the voltage controlled oscillator is adapted such that the difference converges to zero. In this way the VCO is locked to the frequency of the input signal $\tilde{a}_{\text{ref}}(t)$ and will track the reference frequency $f_{\text{ref}}(t)$. The accuracy and robustness of the tracking depends on the settings of the PID controller. The frequency $f_{\text{ref}}(t)$ of the VCO is applied as input for a function generator, which composes the reference signal $\hat{x}_{\text{ref}}(t)$.

EXPERIMENTAL RESULTS

For the present case only tonal control is considered. Three actuators in vertical direction are applied, equidistantly distributed around the circumference of the flange between the pump and the vessel. Three accelerometers close to the actuators and measuring in vertical direction are used as error sensors. An independent accelerometer on the vessel, measuring in radial direction is used as a performance sensor.

While the pump was rotating, measurements were taken with and without tonal control. The scaled accelerations with and without control are given in Figure 4. Reductions on the error sensors at the pump rotation frequency vary from 17 to 72 dB. The strong differences between the vibrations on the three error sensors are due to the internal dynamics of the complete setup. In Figure 4 also the vibrations at the independent performance sensor on the vessel in radial direction are given. The reduction at this sensor was 22 dB.

Measurements were also taken when a fixed reference frequency was applied. In this case it was not possible to achieve any vibration reduction at all. This makes clear that it is absolutely necessary to apply the phase locked loop algorithm to track the small changes in rotation frequency of the pump. Also the application of the IMC correction was very important. Without the application of IMC correction the reductions were limited to just a few dB and the stability of the system was very poor.

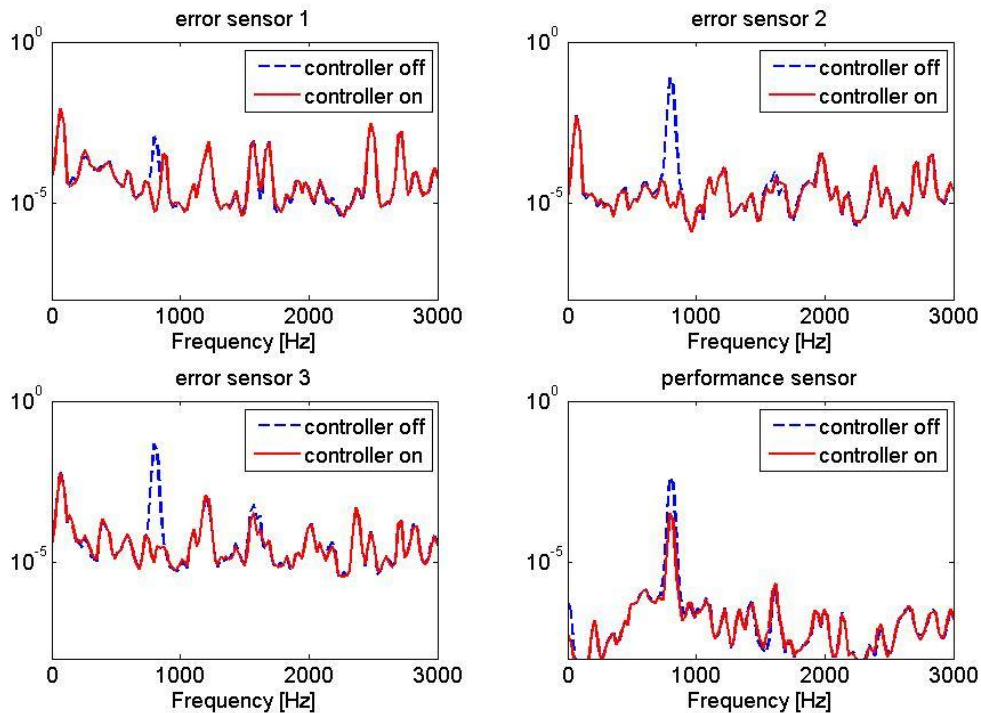

Figure 4 – Measured accelerations (scaled) on error and performance (lower right) sensors with and without the application of control.

DISCUSSION

The initial experiments described in this paper were limited to tonal control. In this stage it is shown that active control is feasible for active isolation of tonal contributions of a turbomolecular pump. In the next stage also multi-harmonic and broadband control will be considered. An implementation of the broadband approach is already available at TNO and will be tested on this setup in the near future.

One of the research questions is how to choose the locations of actuators, error and reference sensors in a proper way making broadband control possible. Furthermore also alternative combination of error criteria will be investigated. By various authors, it is suggested to use error criteria based on a combination of velocity or acceleration sensors and force sensors [4, 5]. In the current research these forces will be measured with piezoelectric strain sensors. A weighted combination of strain and acceleration error sensors will probably give a better performance than the application of only accelerometers.

CONCLUSIONS

With active vibration isolation substantial vibration isolation of a turbomolecular pump can be achieved. A simple strategy giving global reduction with only three actuators is developed. With this approach there is no need for a modification of the connection between the pump and the vessel. The active system is just added at the outside of the connection. In the current stage the strategy is demonstrated to be feasible for tonal control. In the next stages broadband vibration control will also be addressed.

ACKNOWLEDGEMENTS

This research project is supported by the Innovation-oriented Research Program (IOP) Precision Technology, which is carried out by SenterNovem by order of the Dutch Ministry of Economic Affairs.

REFERENCES

- [1] Fuller C.R., Elliott S.J., Nelson P.A., *Active control of Vibration*, Academic Press, London, 1997
- [2] Hansen C.H., Snyder S.D., *Active control of noise and vibration*, E&FN Spon, Heidelberg, New York, 1997
- [3] Horowitz, P. Hill, W. *The art of Electronics*, Cambridge University Press, 1991
- [4] Beijers C.A.J., *A modelling approach to hybrid isolation of structure-borne sound*, PhD Thesis, University of Twente, The Netherlands, 2005
- [5] Gardonio P, Elliott S.J., Pinnington R.J. *Active isolation of structural vibration on a multiple degree-of-freedom system, part II: effectiveness of active control strategies*. Journal of Sound and Vibration, 207(1): 95-121, 1997